



2026 FCCFA Annual Convention & Trade Show

JW Marriott Turnberry

King Ballroom

Miami, FL

July 23 - 25, 2026



Table of Contents



Guidelines for Display.....	3
Labor Rules & Regulations	7
Official Show Information.....	8
Official Service Contractor	10
Method of Payment Form.....	11
Third-Party Billing Agreement.....	12
Payment Terms and Conditions	13
Notification of Intent to Use Non-official Service Contractors.....	18
Example Certificate of Insurance For Exhibitor Appointed Contractors.....	19
Carpet Order Form.....	20
Table Order Form	21
Seating & Accessories Order Form.....	22
Exhibit Rentals.....	23
Booth Labor Order Form	24
Booth Cleaning Order Form	26
Quick Glance - Material Handling Process.....	27
Material Handling & Rates.....	28
Special Handling Definitions	32
Reducing Material Handling Costs.....	33
Freight Re-Route Policy	34
Material Handling Estimate Form.....	36
Outbound Bill of Lading/Shipping Label Request	37
Cartload Service Order Form	38
Terms & Conditions of Contract - Material Handling Services.....	39
ABF Freight.....	45



2026 FCCFA Annual Convention
& Trade Show
JW Marriott Turnberry
Miami, FL
July 23 - 25, 2026

**Discount Price
Deadline Date
JULY 9th**
Method of payment must accompany your order



Guidelines for Display

The guidelines for display have been provided below. This section outlines the standard heights, lengths, and requirements of booths on the exhibit floor and are based on industry standards. We encourage you to review this information prior to planning your booth space.

AUDIO VISUAL/MUSIC/SOUND

In general, the use of sound or audio visual equipment in booths is permitted as long as the noise level does not disrupt the activities of neighboring exhibitors. Speakers and other sound devices should be positioned to direct sound inward (to be contained within the booth) rather than outward (toward aisles and other exhibitor booths). Any devices which project sound must be tuned to conversation level.

BOOTH DESIGNS

Exhibits must be designed, constructed, and operated in good taste and in accordance with the best interests of the event. It is the sole responsibility of exhibitors to camouflage, with a close off, any unsightly or unused booth materials stored behind booth curtains.

STRUCTURAL INTEGRITY

All exhibit displays should be designed and erected in a manner that will withstand normal contact or vibration caused by neighboring exhibitors, hall laborers, or installation/dismantling equipment, such as forklifts. Displays should also be able to withstand moderate wind effects that may occur in the exhibit hall when freight doors are open.

BOOTH HEIGHT

Standard booth (Illustration A) height is 8 feet. No signage or display features will be permitted above this height unless the booth is a perimeter wall booth (Illustration B) in which case the maximum permitted height is 12 feet. If the booth configuration is a peninsula (Illustration C) and/or island (Illustration D) of four booths or more, then maximum height will be 16 feet.

CHILDREN

For safety considerations, children under the age of 12 will not be allowed to enter the exhibit hall, unless accompanied by an adult.

DEMONSTRATIONS (IN BOOTH)

As a matter of safety and courtesy to others, exhibitors should conduct sales presentations, product demonstrations, press conferences and other media events in a manner which assures all exhibitor personnel and attendees of such in-booth events are within the contracted exhibit space and not encroaching on the aisles or neighboring exhibits. Any queue lines formed for exhibitor customer interaction must also be contained within the booth footprint. Exhibitors should be aware of, and adhere to, local regulations regarding fire/safety and environment. Product demonstrations must be held within the exhibitor's space so as not to interfere with any aisle traffic or neighboring exhibitors' booth space (Illustration H).

EXHIBITOR ETIQUETTE

1. Exhibitors shall not congregate or solicit trade in doorways or aisles.
2. Conduct of exhibitors shall be professional and courteous at all times.
3. Exhibitors may not enter the exhibit space of another exhibitor without express permission. If admission has been granted, exhibitors shall be courteous and move aside when the host exhibitor is showing merchandise to prospective buyers.



2026 FCCFA Annual Convention
& Trade Show
JW Marriott Turnberry
Miami, FL
July 23 - 25, 2026

**Discount Price
Deadline Date
JULY 9th**
Method of payment must accompany your order



Guidelines for Display

4. Under no circumstances shall an exhibitor interrupt another exhibitor showing merchandise to a prospective buyer.
5. Exhibitors may not have models, signs, or other solicitation devices outside assigned exhibit space or in aisles.
6. No furniture, product, or packing materials may be left in the aisle during show hours.
7. During educational sessions, please minimize booth noise out of respect for presenters and attendees participating in programming.

HANGING SIGNS AND POSTERS

Signs and posters must be within the booth area and may not be posted on columns or pillars, nor placed in the aisles. Hanging signs are permitted only above peninsulas and/or islands of four booths or more to a maximum of 16 feet. This means that the top of the hanging sign can be no more than 16 feet off the ground. Hanging Signs and Graphics should be set back 10 feet from adjacent booths and be directly over contracted space only. This will be strictly enforced!

ALL HANGING SIGNS MUST BE APPROVED IN ADVANCE OF MOVE-IN BY SHOW MANAGEMENT.

MULTI-STORY OR COVERED EXHIBITS

Exhibit booths that are multi-story or contain covered assembly areas, such as conference areas or theaters, must meet the following minimum life safety requirements:

1. Each enclosed or covered area must be protected by an audible smoke detector. This includes storage closets built into the exhibit.
2. Each enclosed or covered area must display a charged fire extinguisher with a minimum rating of 2A20BC.
3. The maximum occupancy of the load-bearing area(s) in a multi-story exhibit shall be limited to one person per fifteen net square feet of floor space, not to exceed a total of twenty-five persons. This maximum occupancy shall be posted.
4. There should be no less than two means of egress from each load-bearing area in a multi-story exhibit or from each occupied area of a covered assembly area.
5. A fire prevention attendant shall be provided by the exhibitor and shall be on duty at all times, from the time that the enclosure is completed until the time that the enclosure is dismantled or per the local Fire Marshal regulations.

NOISE AND ODORS

Any devices which project sound must be tuned to conversation level. Noisy or obstructive work will not be permitted during exhibit hours, nor will loud operating displays or exhibits producing displeasing odors be allowed.

PAGING

Paging will be restricted to EMERGENCIES ONLY during show hours. Exhibitors requiring emergency help shall report to the Exhibitor Registration Desk or the AGS Exhibitor Service Center.

SET-UP/DISMANTLE

All exhibits must be set-up by the exhibitor on move-in day. No set-up will be allowed during show hours unless approved by Show Management. Dismantle of an exhibit will not be permitted prior to the close of the show. Such action may cause forfeiture of rights to participate in future events.

STAFFING

Exhibit space must be staffed throughout ALL show hours.

Guidelines for Display

STANDARD BOOTH (ILLUSTRATION A)

- Maximum Height:** 8'
- Hanging Signs:** No
- Front Displays:** If over 4' in height, must be placed at least 5' from the aisle line.
- Standard Corner:** Unsightly displays and/or material storage which can be viewed from aisle must be camouflaged at exhibitor's expense. (See the "Booth Close-off's" in the "Furniture & Accessories" form in your Exhibitor Service Manual).

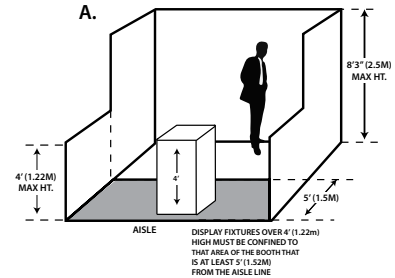

PERIMETER BOOTH (ILLUSTRATION B)

- Maximum Height:** 12' (Drape line is at 8')
- Hanging Signs:** Yes, top can be no more than 12' off the ground. Back wall only.
- Front Displays:** If over 4' in height, must be placed at least 5' from the aisle line.

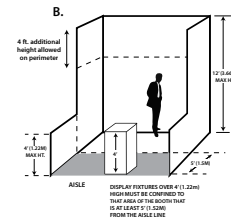

ENDCAP BOOTH

- Maximum Height:** 8'
- Hanging Signs:** No
- Front Displays:** The maximum back wall height allowed is 8ft and the maximum backwall width allowed is 10ft at the center of the backwall with a maximum 5ft height on the two side aisles. Within 5ft of the two side aisles, the maximum height for any display materials is 4ft.

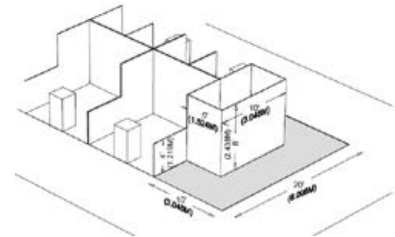

PENINSULA (ILLUSTRATION C)

- Maximum Height:** 16' - 20'
- Hanging Signs:** Yes, top can be no more than 16' off the ground.
- Front Displays:** If over 4' in height, must be placed at least 5' from the aisle line.

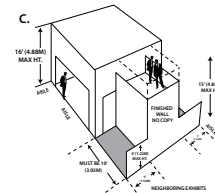

ISLAND (ILLUSTRATION D)

- Maximum Height:** 16' - 20'
- Hanging Signs:** Yes, top can be no more than 16' off the ground.
- Front Displays:** Full use of space is permitted.

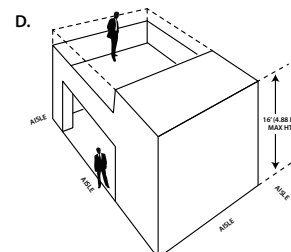

Guidelines for Display

CANOPIES/CEILINGS (ILLUSTRATION E)

- Maximum Height:** 8' - Standard
12' - Perimeter
16' - Island or Peninsula
- Maximum Drape:** 16'
- Maximum Depth:** To full dimensions of contracted space.
- Side Views:** Must contain an opening above 4' high and extending back 5' from the aisle line.
- Fire Code:** Must meet with local fire codes and conform to the minimum life safety requirements.

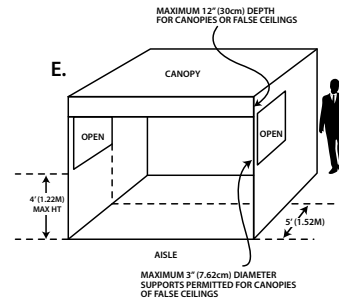

TOWERS (ILLUSTRATION F)

- Maximum Height:** 8' - Standard
12' - Perimeter
16' - Island or Peninsula
- Maximum Depth:** To full dimensions of contracted space.
- Side Views:** Must contain an opening above 4' high and extending back 5' from the aisle line.
- Structural Integrity:** All towers over 12' in height must have blueprints available for inspection, the signature/stamp of a structural engineer, and exhibit company.

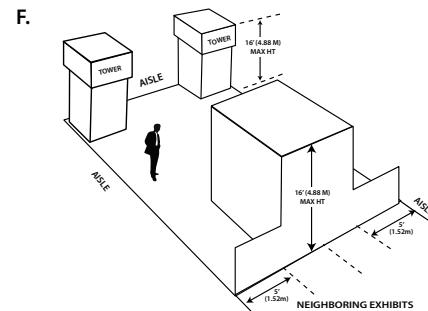

HANGING SIGNS (ILLUSTRATION G)

- Maximum Height:** 16' (to top of sign) Island or Peninsula;
- Maximum Width:** No more than 50% of the total booth length (if placed length-wise). No more than 50% of the total booth width (if placed width-wise).
- Location:** Must be contained within booth. No signs will be allowed on columns, pillars or in aisles.
- Approval:** Must be obtained prior to move-in from Show Management.

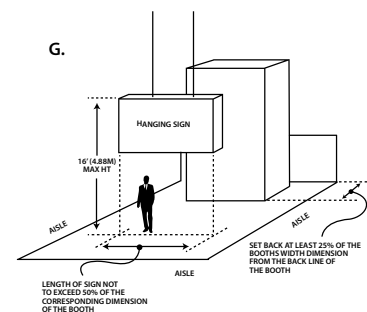

DEMONSTRATIONS (ILLUSTRATION H)

- Location:** Must be contained within the booth area so as not to interfere with aisle traffic or neighboring booth space.
- Samples:** Tables must be set back a minimum of 2' from aisle line
- Audio/Visual:** Must be tuned to conversation level
- Safety Precautions:** Hazard barriers must be provided as needed for moving or potentially dangerous machines.

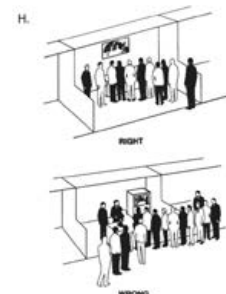



2026 FCCFA Annual Convention
& Trade Show
JW Marriott Turnberry
Miami, FL
July 23 - 25, 2026

**Discount Price
Deadline Date
JULY 9th**
Method of payment must accompany your order



Labor Rules & Regulations

RULES AND REGULATIONS FOR MIAMI, FLORIDA

To assist you in planning for your participation in this upcoming exposition, we ask that you read the following rules and regulations:

EXHIBIT INSTALLATION AND DISMANTLING:

Full-time employees of the exhibiting company may set their own exhibits without assistance from AGS Expo labor. Any labor services that may be required beyond what your regular full-time employees can provide must be rendered by the AGS Expo Services. Labor can be ordered in advance by returning the Display Labor form, or on show site at the AGS Service Center.

MATERIAL HANDLING:

Exhibitors may hand-carry their own materials into the exhibit facility; however, the use or rental of dollies, flat trucks, pallet jacks, and other mechanical equipment is not permitted. Only full-time employees of the exhibiting company will be allowed to hand-carry items. AGS Expo Services will control access to the loading docks in order to provide for a safe and orderly move-in/out. Unloading or reloading at the dock of any and all contracted carriers must be handled by AGS Expo Services.

TIPPING:

AGS Expo Services requests that exhibitors do not tip our employees. They are paid at an excellent wage scale denoting a professional status, and we feel that tipping is not necessary. This applies to all employees. Any request for such should be brought to the attention of an AGS representative at the service desk or correspondence may be directed to the attention of the General Manager at the office address.

SAFETY:

Standing on chairs, tables, or other rental furniture is prohibited. This furniture is not engineered to support your standing weight. AGS Expo Services cannot be responsible for injuries or falls caused by the improper use of this furniture. If assistance is required in assembling your booth, please order labor on the Display Labor order form and the necessary ladders and tools will be provided. Closed-toe shoes are required during all move-in and move-out periods. For safety reasons, closed-toe shoes are required during all move-in and move-out periods, and open-toe footwear is not permitted in the exhibit hall/in the dock area while freight and equipment are in operation.



2026 FCCFA Annual Convention
& Trade Show
JW Marriott Turnberry
Miami, FL
July 23 - 25, 2026

**Discount Price
Deadline Date
JULY 9th**

Method of payment must accompany your order



Official Show Information

As the Official Service Contractor for 2026 FCCFA Annual Convention & Trade Show, AGS Expo Services would like to say welcome! The information below is only a brief summary of the important times, dates, addresses, and details regarding your event. More detailed information has been provided in each section of this Exhibitor Service Manual and at www.ags-expo.com.

Show Information

OFFICIAL SERVICE CONTRACTOR

AGS Expo Services	Phone: 407.292.0025
4561 SW 34th Street	Fax: 407.292.4414
Orlando, FL 32811	Email: eventservices@ags-expo.com

EXHIBIT HALL INFORMATION

Exhibit Hall(s): King Ballroom

Backwall Drape: Black

Siderail Drape: Black

Booth Carpet Color: Hall is carpeted - Multi-Color

Aisle Carpet Color: N/A

Booth Equipment

<p>Booth Size: 8' x 10'</p> <p>Includes: 8'H Backwall Pipe and Drape 3'H Siderail Pipe and Drape ID Sign (1) 6' x 30" Black Skirted Table (2) Plastic Folding Chairs (1) Wastebasket</p>	<p>Booth Size: 6' x 8' Table Tops</p> <p>Includes: 3'H Siderail Pipe and Drape ID Sign (1) 6' x 30" Black Skirted Table (2) Plastic Folding Chairs (1) Wastebasket</p>
--	--

Show Schedule

EXHIBITOR MOVE-IN

Thursday July 23, 2026 1:00 PM - 6:00 PM
Booths must be set by 6:00 PM

EXHIBIT HOURS

Thursday July 23, 2026 6:30 PM - 7:30 PM
Welcome Reception

Friday July 24, 2026 8:45 AM - 5:30 PM

Saturday July 25, 2026 8:00 AM - 12:00 PM

EXHIBITOR MOVE-OUT

** Immediately when show closes at 12:00 PM **

Saturday July 25, 2026 12:00 PM - 2:00 PM

Other Details

- Empty crates and cartons will be returned beginning at **12:01 PM on Saturday, July 25th**
- All carriers must check-in no later than **1:00 PM on Saturday, July 25th**
- All exhibitor materials must be removed from the exhibit facility by **2:00 PM on Saturday, July 25th**
- **Freight Re-Route Deadline:** All unconsigned materials remaining on the event floor will be re-routed via the official show carrier, ABF Freight at **1:01 PM on Saturday, July 25th**

OFFICIAL SHOW INFORMATION



2026 FCCFA Annual Convention
& Trade Show
JW Marriott Turnberry
Miami, FL
July 23 - 25, 2026



AGS Exhibitor Service Center Hours

AGS Expo production personnel will be available on-site to assist you with furniture, rental exhibits, labor, cleaning, and material handling. We are available during move-in, move-out, and exhibit hours.

For the AGS on-site Service Center phone number, please call our main office during business hours at 407.292.0025 or email us at eventservices@ags-expo.com

Shipping Information

Below is the direct shipping addresses for your event. Please know that a Method of Payment must be on file to receive your materials for the event

Direct Shipments to Exhibit Site

[Company Name] - [Booth #]
2026 FCCFA Annual Convention & Trade Show
AGS Expo Services
c/o JW Marriott Miami Turnberry Resort & Spa
King Ballroom
19999 West Country Club Drive
Adventura, FL 33180

Delivery Window

- Thursday, July 23, 2026 - 1:00 PM - 6:00 PM
- All booths must be set by 6:00 PM on Thursday, July 23, 2026

Discount Deadlines & Policy Reminders

Take advantage of our substantial price discounts. To get our lower prices, return your order with payment by the discount deadline(s) on the order forms provided.

Show Order Discount Deadline - July 9, 2026

Please review our payment policy carefully. As a reminder, AGS Expo Services requires payment in full at the time your order is placed along with a completed Method of Payment Form. This may be used to cover on-site charges such as labor and material handling, not included with your initial payment.

It is important to review the local labor and/or Union jurisdiction policies located in this Service Manual. Policies vary by state and location.

Please contact our Event Services Department with questions or special requests. We will provide you with all of your show needs and appreciate the opportunity to work with you.



2026 FCCFA Annual Convention
& Trade Show
JW Marriott Turnberry
Miami, FL
July 23 - 25, 2026



Official Service Contractor

Show management, acting on behalf of all exhibitors and in the best interest of the exposition, has appointed AGS Expo Services as the official service contractor to perform and provide necessary services and equipment.

Official service contractors are appointed to:

- a. Ensure the orderly and efficient installation and removal of the overall exposition.
- b. Assure the distribution of labor to all exhibitors according to need.
- c. Provide sufficient labor to satisfy the requirements of exhibitors and for the exposition itself.
- d. See that the proper type and limits of insurance are enforced.
- e. Avoid any conflict with local Union and/or exhibit hall regulations and requirements.

Exceptions are:

- f. Supervision may be provided by the exhibitor.
- g. The exhibitor may appoint an exhibit installation contractor or display builder.

Exhibitor Appointed Contractors (EACs)

Exhibitors may employ the service of independent contractors to install and dismantle their exhibit, providing the exhibitor and the installation and dismantle contractor comply with the following requirements:

1. The exhibitor must notify, in writing, show management and AGS Expo Services of the intention to utilize an independent contractor no later than 30 days prior to the first move-in day by completing the Notification of Intent to Use Non-official Service Contractors Form contained in this Service Manual.
2. The exhibitor shall provide evidence that the Exhibitor Appointed Contractor (EAC) has a proper certificate of insurance with a minimum of \$1,000,000 liability coverage including property damage and Worker's Compensation naming AGS Expo Services as additional insured to show management and AGS Expo Services no later than the deadline date listed for EACs.
3. The exhibitor agrees that they are ultimately responsible for all services in connection with their exhibit including freight, drayage, rentals, and labor.
4. The EAC must have all business licenses, permits, and Worker's Compensation Insurance required by the state and city governments and the convention facility management prior to commencing work and shall provide show management with evidence of compliance.
5. The EAC will share with AGS Expo Services all reasonable costs related to its operation including overtime to pay for stewards' restoration of exhibit space to its initial condition, etc.
6. The EAC will provide AGS with the names of all on-site employees who will be working on the exposition floor and see that they have and wear at all times necessary identification badges as determined by show management or the facility.
7. The EAC must be able to provide evidence that it has a valid authorization from the exhibitor for services. The EAC may not solicit business on the exhibit floor.
8. The EAC must confine its operations to the exhibit area of its clients. No service desks, storage areas, or other work facilities will be located anywhere in the building. The show aisles and public spaces are not a part of the exhibitor's booth space.
9. The EAC shall provide, if requested, evidence to AGS Expo Services that it possesses applicable and current labor contracts and must comply with all labor agreements and practices.
10. The EAC must not commit, or allow to be committed by persons in its employment, any acts that could lead to work stoppages, strikes or labor problems.
11. The exposition floor, aisles, loading docks, service, and storage areas will be under the control of the official service contractor, AGS Expo Services. The EAC must coordinate all of its activities with AGS Expo Services.
12. For services such as electrical, plumbing, telephone, cleaning, and drayage, no contractor other than the official service contractor will be approved. This regulation is necessary because of licensing, insurance, and work done using equipment and facilities owned by parties other than the exhibitor. Exhibitors shall provide only the material and equipment they own and to be used in their exhibit space.



Company Name	Tel #	Booth Number
Billing Address	Email	
City / State / Zip	Signature	

All exhibitors are required to have a credit card on file as a primary method of payment.

Credit Card Authorization Form

For your convenience, we will use this authorization to charge your credit card account for your advance orders and any additional amounts incurred as a result of show site orders placed by your representative. **For Third-Party payers please use "Third Party Billing Agreement" form.** Please complete the information requested below:

Personal	Company	Visa	Mastercard	American Express
Card Number: _____		Exp. Date: _____		
Card Holder's Name (Print) _____		CVV: _____		
Signature: _____				
Credit Card Billing Address: _____				
City: _____		State: _____		Zip: _____

Account Option *(please select one)*

Keep this Method of Payment on file for future events **OR** Use for this event only

• By providing your signature, you hereby accept all the terms and conditions contained in this Service Manual.

Company Check

- Please make all checks payable to: **AGS Exposition Services, Inc.**
- All checks must be in **U.S. currency.**
- Please print show name and booth number.
- Company checks must be received 14 days prior to exhibitor move-in to provide adequate time for processing
- Orders are processed and appropriate discounts (if any) are applied on the date that your payment is received. A copy of your check by email, fax, etc. is not considered payment.
- **Credit Card Authorization MUST be on file with AGS Expo Services before any goods or services are rendered regardless of your preferred method of payment.**

Check Number: _____

Amount Due: _____

Wire Transfers

If you wish to make a payment via Wire Transfer, please call 407-292-0025, or email us at eventservices@ags-expo.com, to obtain bank information and routing identifiers.

****Additional fees apply***

Full payment must accompany order. PLEASE, NO TELEPHONE ORDERS.

Credit Card Authorization MUST be on file with AGS Expo Services before any goods or services are rendered regardless of your preferred method of payment. By utilizing this form, exhibitors acknowledge that they have read and agree to comply with the terms of the Limits of Liability statements contained herein.

AGS Expo Services • 4561 SW 34th Street • Orlando, FL 32811
 Phone: 407.292.0025 • Fax: 407.292.4414

Email: eventservices@ags-expo.com Order Online: www.ags-expo.com

METHOD OF PAYMENT FORM



2026 FCCFA Annual Convention
& Trade Show
JW Marriott Turnberry
Miami, FL
July 23 - 25, 2026

**Discount Price
Deadline Date
JULY 9th**
Method of payment must accompany your order



Third-Party Billing Agreement

As an exhibitor electing to use a third-party for my billable services, I understand and hereby agree that the ultimate responsibility for payment of all charges is mine. Further, I agree to be bound by all terms and conditions outlined in the Payment Terms and Conditions within this Exhibitor Service Manual. In the event that the named third-party fails to meet the required payment terms, charges will revert back to me, the exhibiting company. **All invoices are due and payable upon receipt, by either party.**

Exhibiting Firm

Exhibitor Company Name:		Booth #:
Exhibitor Contact Name:		
Phone:	Email:	
Address:		
City:	State:	Zip:
Exhibitor Signature (Required):		

Third-Party

The following items are to be charged to the Third-Party:

All Services OR Furniture/Carpet Material Handling Booth Cleaning Labor

Third-Party Company Name:		
Contact Name:		
Phone:	Email:	
Address:		
City:	State:	Zip:
Third-Party Payer Signature (Required):		

Third-Party Credit Card Information:

Payment in full must accompany your order. Please note, we will use this authorization to charge your credit/debit card account for all orders noted above, at anytime, including those placed onsite by your representative. These charges may include all services provided by AGS Expo Services including but not limited to material handling, labor, and product orders. For tax-exempt status, within the state of the event, please submit a tax-exempt certificate. **We gladly accept VISA, Mastercard and American Express.**

Credit Card Number:	Exp. Date:
Card Holder's Name:	CVV:
Signature:	
Credit Card Billing Address:	
City:	State:
Zip:	

AGS Expo Services • 4561 SW 34th Street • Orlando, FL 32811
Phone: 407.292.0025 • Fax: 407.292.4414

Email: eventservices@ags-expo.com Order Online: www.ags-expo.com

THIRD-PARTY BILLING AGREEMENT



2026 FCCFA Annual Convention
& Trade Show
JW Marriott Turnberry
Miami, FL
July 23 - 25, 2026

Discount Price
Deadline Date
JULY 9th

Method of payment must accompany your order



Payment Terms and Conditions

1. Definitions & Scope

Customer means the party ordering Services or Goods from AGS. Engagement means any work AGS performs, including an Event (e.g., trade show, conference, or similar) or a Project (non-event work such as graphics/print). Exhibitor means a Customer participating in an Event. Site means the venue, facility, or other delivery/installation location. Goods means items rented or sold by AGS. Services means services AGS provides, including without limitation rental of equipment and furnishings, installation/dismantle, on-site services, logistics coordination, graphics/print, and related services. Order/Quote/SOW means documents describing scope, schedule, quantities, and pricing for an Engagement. Deliverables means the finished output of Services or Goods delivered (e.g., printed graphics).

These Terms bind Customer, AGS, and their respective permitted agents and representatives.

2. Agreement to Terms & Establishment of Company Account

By submitting a signed Method of Payment Form, Customer agrees to these Terms and all related service forms applicable to Customer and its agents. Alternatively, Customer may agree to these Terms through the Method of Payment submission process on AGS's online ecommerce platform(s). Such acceptance requires Customer (or its authorized account holder) to provide a valid email address as an electronic signature before beginning the ordering process. Acceptance through the ecommerce platform(s) is binding on Customer and its agents to the same extent as a signed Method of Payment Form. When selecting "Keep this Method of Payment on file for future events," Customer establishes a company account with AGS for one (1) calendar year, covering all active and future transactions regardless of Engagement. Customer is responsible for maintaining an active credit card on file, regardless of account balance. Third-party credit cards, when identified on the Method of Payment Form, are exempt and will instead establish a single event/project account for the period of service.

3. Rental Basis for Materials and Equipment

All materials and equipment provided by AGS are furnished on a rental basis and remain the sole property of AGS

unless explicitly identified as a sale.

4. Limitation of Liability

AGS shall not be liable for any indirect, incidental, special, or consequential damages, including lost profits or business opportunities, arising from the use of or inability to use AGS's Services, equipment, or materials. AGS's liability shall in no event exceed the total fees paid by Customer for the specific Service giving rise to the claim.

5. Indemnification

Customer agrees to indemnify, defend, and hold harmless AGS, its officers, employees, and agents from and against any and all claims, liabilities, damages, losses, and expenses (including reasonable attorneys' fees) arising out of or resulting from Customer's negligence, breach of these Terms, violation of applicable law, or use of AGS equipment or Services.

6. Force Majeure

Neither AGS nor Customer shall be liable for delays or failure in performance caused by acts of God, natural disasters, government actions, labor disputes, pandemics, or other events beyond their reasonable control. Obligations for Services rendered prior to such events remain enforceable and payable.

7. Insurance Requirements; No Insurance by AGS

Customer shall maintain appropriate liability and property insurance coverage during the Engagement, including coverage for damages to Customer property, rented equipment, and third-party claims, in commercially reasonable amounts. Upon request, Customer shall provide AGS with a certificate of insurance evidencing such coverage.

No Insurance by AGS; Risk of Loss. AGS is not an insurer and does not provide insurance for Customer's property. Risk of loss or damage to Customer's property remains with Customer at all times; Customer is responsible for maintaining appropriate insurance for its property.

8. Payment Terms

a. Payment of Balances All Orders must be accompanied by a Method of Payment Form. AGS accepts payments in U.S. funds via company check, Visa, MasterCard, or American Express. Any Order submitted without a valid



2026 FCCFA Annual Convention
& Trade Show
JW Marriott Turnberry
Miami, FL
July 23 - 25, 2026

Discount Price
Deadline Date
JULY 9th

Method of payment must accompany your order



Payment Terms and Conditions

payment method, or with an outstanding balance, will be charged to the primary credit card on file.

b. Credit Card Requirement A zero balance does not waive the requirement to maintain a valid credit card on file.

c. Wire or ACH Funds Transfers AGS may accept Wire or ACH transfers for open or advance deposits. A valid credit card must remain on file regardless. Transfers must be noticed to AGS via a trackable carrier service with details (Engagement/Event, company name, booth number if applicable, and Services covered) and received at least ten (10) business days before the first day of move-in or scheduled start. Failure to properly notice transfers may result in AGS's inability to guarantee crediting of funds. Fees imposed by financial institutions and AGS policy apply. AGS may withhold Services for payment deficiencies arising from such fees.

d. Payment Method Changes If Customer requests any change to the payment method after an Order has been submitted or processed — including, without limitation, (i) transferring balances between credit cards or other payment methods within the same account, (ii) substituting a different credit card or payment method for all or part of an existing Order, or (iii) reprocessing charges previously applied — AGS may assess a Payment Change Fee. This fee may be calculated as (a) a percentage of the amount transferred or reprocessed, not to exceed seven percent (7%), or (b) a flat convenience/reprocessing fee in an amount reasonably determined by AGS, depending on the nature of the request and administrative costs incurred.

e. Credit Authorization AGS reserves the right to verify available credit on any card presented. If Customer fails to review or settle invoices before Engagement close (for Events, before Event close), charges will automatically be applied to the credit card on file.

f. Discount Eligibility Discounts are available only if advance Orders are accompanied by payment and received prior to the published Order deadline date.

g. Payment Upon Presentation Full payment is required upon presentation of invoices/statements (including at the Site for Events). Customer must settle all accounts prior to Engagement close (for Events, prior to Event close).

h. Company Check Payments Company checks must be received at least fourteen (14) days prior to move-in or

scheduled start. Regardless, a credit card is required on file. Returned checks will incur a Non-Sufficient Funds fee.

i. No Cash Acceptance On Site Cash payments are prohibited on Site, except where AGS expressly approves in writing.

j. Right to Withhold Services or Release of Orders for Non-Payment AGS may suspend or withhold Services, including release of rented equipment or additional Orders, until past-due amounts are paid in full.

k. Prepayment Requirement After Delinquency Following any delinquency or history of disputes, AGS may require full prepayment for future Services.

9. Account Audits and Adjustments

No invoice or statement shall be deemed final. AGS reserves the right to audit and adjust accounts before, during, or after an Engagement. Services such as, but not limited to, Labor, Material Handling, Furnishings, and custom or quoted items are estimates subject to final billing upon completion. Any adjustments will be billed to the payment method on file or must be paid upon invoice presentation.

10. Responsibility for Payments

Customer remains ultimately responsible for payment of all labor, equipment, and Services, whether ordered by Customer, its display builder, contractors, or other authorized parties.

11. Exhibitor-Appointed Contractors (EACs)

a. Responsibility Customer remains fully responsible for all Services, labor, and equipment ordered on its behalf, including those arranged, performed, or supervised by an exhibitor-appointed contractor ("EAC"). Engaging an EAC does not relieve Customer of any payment, liability, or compliance obligations under these Terms.

b. Payment Default If an EAC or other third-party acting for Customer fails to remit payment for any Services or Goods provided by AGS, Customer authorizes AGS to charge Customer's primary payment method on file for any unpaid balances. Such amounts shall be deemed Customer's direct obligation to AGS.

c. Insurance and Authorization All EACs must submit to AGS, prior to move-in: (i) a current certificate of insurance



2026 FCCFA Annual Convention
& Trade Show
JW Marriott Turnberry
Miami, FL
July 23 - 25, 2026

Discount Price
Deadline Date
JULY 9th

Method of payment must accompany your order



Payment Terms and Conditions

naming AGS Exposition Services, Inc. as an additional insured on a primary and non-contributory basis for commercial general liability coverage customary for trade-show contractors; and (ii) a completed EAC Authorization Form approved by AGS. AGS may deny, suspend, or revoke EAC access to the Site for failure to provide required documentation or for unsafe or non-compliant conduct.

d. Compliance and Conduct EACs must comply with all facility, event, and safety rules, including union jurisdiction and time restrictions. Customer is responsible for ensuring such compliance and shall defend, indemnify, and hold harmless AGS from any claims, damages, or penalties arising from acts or omissions of any EAC, its employees, or subcontractors

12. Purchase Orders

Where a purchase order is required, it must accompany the Order form(s). This requirement applies equally to government agencies.

13. Taxes

Customer is responsible for any excise, property, sales, use, or other taxes imposed under applicable federal, state, or municipal tax laws. Products, Services, labor, and cancellation fees (including amounts due for partially rendered or non-cancellable Services or Goods) may be taxable depending on the jurisdiction in which the Engagement occurs. AGS operates on an accrual basis for accounting and tax purposes, as Services are provided over time and across multiple jurisdictions. Accordingly, tax obligations are assessed at the point when taxable Products, Services, or fees become due — which shall be the later of (i) the date of the applicable Event close, (ii) the effective date of cancellation or non-participation, or (iii) the date on which preparatory or partially rendered Services are performed — and are binding regardless of the date of invoicing or payment. If a tax code or rate changes after publication of an Order form but before fulfillment, AGS will adjust invoices as required by law. Customers claiming tax-exempt status must provide a valid exemption certificate for the state in which Services are delivered. Resale certificates are valid only if charges are being re-billed to Customer's customers.

14. Payment Disputes

a. Chargebacks and Disputes Customers disputing charges through their merchant or banking institution may be assessed fees equal to those imposed by the processor. If the dispute is resolved in favor of AGS, Customer is liable for those fees in addition to any outstanding balances.

b. Dispute of Authorized Charges Once Services are rendered, authorized charges may not be disputed unless a formal complaint is submitted in writing, either by email or via notation on an existing invoice, to an AGS Representative (including on-site for Events).

15. Claims, Notices & Suit Limitation; No Set-off

a. Service Issue Escalation & Credits Customer must promptly notify an AGS Representative of any service issue in order to allow corrective action during the Engagement and for any possible credit to be considered.

For Events: notice must be given on-site and before Event close.

For Projects: notice must be given within two (2) business days of delivery/installation.

Failure to provide notice within these windows waives Customer's right to request corrections or credits for the issue. Invoices are sent to the primary email on file during the Engagement, and no credits will be issued for unreported, missing, or incomplete Orders after the applicable notice window.

b. Incident Reporting and Formal Claims In addition to the escalation requirements above, any incident that Customer intends to pursue as a claim must also be reported in writing within twenty-four (24) hours of discovery and no later than Engagement close (for Events, no later than Event close). A formal written claim detailing the alleged issue must then be submitted to AGS within thirty (30) days after Engagement close (for Events, after Event close). Claims submitted after this period will not be accepted.

c. Limitation Period for Legal Actions Any lawsuit, arbitration, or other legal proceeding relating to these Terms must commence within one (1) year after Engagement close (for Events, after Event close). Claims not filed within this period are permanently barred.



2026 FCCFA Annual Convention
& Trade Show
JW Marriott Turnberry
Miami, FL
July 23 - 25, 2026

Discount Price
Deadline Date
JULY 9th

Method of payment must accompany your order



Payment Terms and Conditions

16. Delinquency and Payment Enforcement

a. Outstanding Balances and Collections Balances not paid within twenty (20) days following Engagement close (for Events, following Event close) are subject to collection action. A service charge of 1.5% per month (18% annually) will apply to past-due accounts. Fees for insufficient funds on personal or company checks will be added to the account.

b. Service Refusal AGS reserves the right to refuse Service to Customers with outstanding balances or a history of delinquency or disputes. AGS may require prepayment or specific payment methods in such circumstances.

16. Refunds

Refunds of less than thirty-five dollars (\$35) must be requested by Customer or an authorized third party. Any approved adjustments or credits explicitly noted on invoices will be returned to the original method of payment within thirty (30) days after Engagement close (for Events, after Event close). Credit card refunds may require additional posting time as determined by the card issuer. No adjustments will be made for currency fluctuations.

17. Order Cancellations

Cancellations resulting from Customer non-participation or Engagement cancellation are subject to fees ranging from fifty percent (50%) to one hundred percent (100%) of the total Order. General cancellations may also incur 50–100% fees, as specified on individual Order forms.

Made-to-Order Goods For custom or made-to-order Goods (including printed graphics), Orders are non-cancellable once production begins; Customer remains responsible for all costs incurred.

18. Artwork & Proof Approval (Graphics/Print)

Customer is responsible for the accuracy, rights, and lawfulness of all submitted artwork/files. Unless otherwise agreed in writing, AGS will produce from the last written proof approval. Minor color variation may occur due to substrate/ink/press differences; AGS will make commercially reasonable efforts to achieve requested color targets but does not guarantee color matching absent a paid color-managed proof.

19. Shipping & Title for Sold Goods (Non-Rental)

For Goods sold (not rented), title and risk of loss pass to Customer upon delivery to the carrier at AGS's dock (FOB Origin) unless otherwise stated in the Order. Transit claims must be filed with the carrier.

20. Material Handling & Labor Services

For any services involving shipping, drayage, material handling, warehousing, or event labor (including installation and dismantle), AGS's Terms and Conditions of Contract for Material Handling and Labor Services also apply. Those terms are available at <http://www.ags-expo.com/terms/material-handling-&-labor> and are part of this agreement. If there's ever a conflict between the two, the Material Handling Terms will govern those specific services.

21. Deliverables Acceptance (Projects)

For Projects, Deliverables are deemed accepted unless Customer provides a written, itemized rejection within five (5) business days of delivery/installation describing the non-conformity in reasonable detail. Any rejection or related claim must also comply with the notice and claims procedures in Section 14.

22. Governing Law & Venue

These Terms are governed by the laws of the State of Florida, without regard to conflict-of-law principles. The parties consent to the exclusive jurisdiction and venue of the state or federal courts located in Orange County, Florida.

22. Severability

If any provision of these Terms is determined to be invalid, illegal, or unenforceable in any respect, the remaining provisions shall remain valid, binding, and enforceable to the fullest extent permitted by law.

23. Order of Precedence

If there is a conflict, the following govern in descending order: (1) a mutually executed master agreement or SOW; (2) the Order/Quote; (3) these Terms.



2026 FCCFA Annual Convention
& Trade Show
JW Marriott Turnberry
Miami, FL
July 23 - 25, 2026

Discount Price
Deadline Date
JULY 9th

Method of payment must accompany your order



Payment Terms and Conditions

24. Amendments; Modifications

AGS may revise or update these Terms from time to time in its sole discretion. Any such changes will be effective upon posting to AGS's website or ecommerce platform(s), or upon written notice to Customer. Continued use of AGS's Services, placement of Orders, or submission of a Method of Payment Form after such notice constitutes Customer's acceptance of the revised Terms.

25. Waiver

The failure of AGS to enforce any provision of these Terms shall not be construed as a waiver of its right to enforce that provision or any other provision at a later time.

26. Notices

All notices, requests, demands, or other communications required or permitted under these Terms must be in writing and delivered by (i) email with read receipt requested, or (ii) nationally recognized courier or other trackable mail service. Notices to AGS shall be directed as follows:

- For contract or legal issues: accounting@ags-expo.com
- For claims only: claims@ags-expo.com
- Physical mailing: AGS Exposition Services, Inc., 4561 SW 34th Street, Ste A, Orlando, FL 32811

Notices to Customer shall be sent to the primary email address or physical mailing address provided by Customer on the Order or Method of Payment Form. Notices are deemed effective (a) if by email, upon transmission with read receipt confirmation, and (b) if by courier or trackable mail, upon delivery confirmation. Failure of Customer to maintain current contact information does not invalidate notice properly sent to the last known address on file with AGS.

27. Entire Agreement

These Terms, together with any applicable Order/Quote/SOW, constitute the entire agreement between AGS and Customer regarding the subject matter hereof, and supersede all prior or contemporaneous understandings, agreements, negotiations, or communications, whether written or oral, relating to such subject matter. No amendment or modification is valid unless in writing and issued by AGS.



Company Name	Tel #	Booth Number
Billing Address	Email	
City / State / Zip	Signature	



Notification of Intent

Exhibitors who plan to have a Non-official Service Contractor (also known as an Exhibitor Appointed Contractor) unpack, erect, assemble, dismantle, and pack displays/equipment must submit this form and abide by the rules set forth in this Service Manual.

Please provide the following information:

Non-official Contractor Information (PLEASE PRINT OR TYPE)

Service Firm:	Phone:
Firm Contact:	Fax:
On-site Exhibitor Contact:	Cell Phone:
Address:	
Email Address:	

Please specify EAC's role: ___ **Ordering Services** ___ **Paying for Services (3PP)** ___ **I&D Services**

Basic Requirements

1. The exhibitor must notify AGS Expo Services of its intent to use a Non-official Contractor by:

Notification Deadline: Thursday, June 25, 2026

- Non-official Contractors must submit proof of adequate insurance in the form of an original policy rider listing AGS Expo Services as additionally insured, furnished by their broker, to AGS Expo Services no later than the deadline date listed. This must include a copy of your Worker's Compensation Insurance Policy. Please see the following page for an example certificate.
- All booth personnel must wear proper identification at show site.
- If your exhibit services firm is a third party and will be billed for services at the event, please ensure your firm submits the Third-Party Billing Agreement.

Please Note:

- If the exhibiting company or Non-official Contractor fails to comply with any or all of the requirements, the Non-official Contractor will not be permitted to service your exhibit and AGS Expo Services must be hired for installation and dismantle labor. The Non-official Contractor will be able to provide supervision only. Please see the section titled Official Service Contractors and Exhibitor Appointed Contractors for a complete list of rules.**
- To confirm that your contractor can perform services at this event, please contact our Events Services Department.
- Any unpaid balances remain the ultimate responsibility of the exhibitor.

NOTIFICATION OF INTENT TO USE NON-OFFICIAL SERVICE CONTRACTORS



2026 FCCFA Annual Convention
& Trade Show
JW Marriott Turnberry
Miami, FL
July 23 - 25, 2026

Deadline Date
JUNE 25th



EXAMPLE CERTIFICATE OF INSURANCE FOR EXHIBITOR APPOINTED CONTRACTORS

CERTIFICATE OF LIABILITY INSURANCE

DATE (MM/DD/YYYY)
06/06/2016

THIS CERTIFICATE IS ISSUED AS A MATTER OF INFORMATION ONLY AND CONFERS NO RIGHTS UPON THE CERTIFICATE HOLDER. THIS CERTIFICATE DOES NOT AFFIRMATIVELY OR NEGATIVELY AMEND, EXTEND OR ALTER THE COVERAGE AFFORDED BY THE POLICIES BELOW. THIS CERTIFICATE OF INSURANCE DOES NOT CONSTITUTE A CONTRACT BETWEEN THE ISSUING INSURER(S), AUTHORIZED REPRESENTATIVE OR PRODUCER, AND THE CERTIFICATE HOLDER.

IMPORTANT: If the certificate holder is an ADDITIONAL INSURED, the policy(ies) must be endorsed. If SUBROGATION IS WAIVED, subject to the terms and conditions of the policy, certain policies may require an endorsement. A statement on this certificate does not confer rights to the certificate holder in lieu of such endorsement(s).

PRODUCER INSURANCE AGENT/BROKER NAME 1. STREET ADDRESS CITY, STATE, ZIP PHONE:	CONTACT NAME: YOUR AGENT'S NAME PHONE (A/C, No, Ext): 555-555-5555 FAX (A/C, No): 555-555-5555 E-MAIL ADDRESS: YOUR AGENT'S EMAIL ADDRESS
INSURED 2. NAME OF INSURED. **THIS MUST BE THE LEGAL NAME OF THE CONTRACTING PARTY, THE EXHIBITOR-APPOINTED CONTRACTOR.**	INSURER(S) AFFORDING COVERAGE INSURER A: GENERAL LIABILITY INSURER NAME INSURER B: AUTOMOBILE LIABILITY INSURER NAME INSURER C: UMBRELLA LIABILITY INSURER NAME INSURER D: WORKERS' COMP LIABILITY INSURER NAME INSURER E: INSURER F:

COVERAGES **CERTIFICATE NUMBER:** **REVISION NUMBER:**

THIS IS TO CERTIFY THAT THE POLICIES OF INSURANCE LISTED BELOW HAVE BEEN ISSUED TO THE INSURED NAMED ABOVE FOR THE POLICY PERIOD INDICATED. NOTWITHSTANDING ANY REQUIREMENT, TERM OR CONDITION OF ANY CONTRACT OR OTHER DOCUMENT WITH RESPECT TO WHICH THIS CERTIFICATE MAY BE ISSUED OR MAY PERTAIN, THE INSURANCE AFFORDED BY THE POLICIES DESCRIBED HEREIN IS SUBJECT TO ALL THE TERMS, EXCLUSIONS AND CONDITIONS OF SUCH POLICIES. LIMITS SHOWN MAY HAVE BEEN REDUCED BY PAID CLAIMS.

INSR LTR	TYPE OF INSURANCE	ADDL INSR	SUBR	POLICY NUMBER	POLICY EFF (MM/DD/YYYY)	POLICY EXP (MM/DD/YYYY)	LIMITS
A	GENERAL LIABILITY 3. <input checked="" type="checkbox"/> COMMERCIAL GENERAL LIABILITY <input type="checkbox"/> CLAIMS-MADE <input checked="" type="checkbox"/> OCCUR GEN'L AGGREGATE LIMIT APPLIES PER: <input type="checkbox"/> POLICY <input type="checkbox"/> PRO-JECT <input type="checkbox"/> LOC	Y	Y	POLICY # INSURER A	00/00/0000	00/00/0000	8. EACH OCCURRENCE \$ 1,000,000 DAMAGE TO RENTED PREMISES (EA occurrence) \$ 100,000 MED EXP (Any one person) \$ 5,000 PERSONAL & ADV INJURY \$ 1,000,000 GENERAL AGGREGATE \$ 2,000,000 PRODUCTS - COM/OP AGG \$ 2,000,000
	AUTOMOBILE LIABILITY <input checked="" type="checkbox"/> ANY AUTO ALL OWNED AUTOS <input checked="" type="checkbox"/> HIRED AUTOS <input checked="" type="checkbox"/> SCHEDULED AUTOS NON-OWNED AUTOS	Y	Y	POLICY # INSURER B	00/00/0000	00/00/0000	COMBINED SINGLE LIMIT (EA accident) \$ 1,000,000 BODILY INJURY (Per person) \$ BODILY INJURY (Per accident) \$ PROPERTY DAMAGE (Per accident) \$
C	UMBRELLA LIAB <input checked="" type="checkbox"/> OCCUR EXCESS LIAB <input type="checkbox"/> CLAIMS-MADE DED RETENTION \$	Y	Y	POLICY # INSURER C	00/00/0000	00/00/0000	EACH OCCURRENCE \$ 2,000,000 AGGREGATE \$ 2,000,000
D	WORKERS COMPENSATION AND EMPLOYERS' LIABILITY ANY PROPRIETOR/PARTNER/EXECUTIVE OFFICER/MEMBER EXCLUDED? (Mandatory in NH) If yes, describe under DESCRIPTION OF OPERATIONS below	Y/N	N/A	POLICY # INSURER D	00/00/0000	00/00/0000	E.L EACH ACCIDENT \$ 1,000,000 E.L DISEASE - EA EMPLOYEE \$ 1,000,000 E.L DISEASE - POLICY LIMIT \$ 1,000,000

DESCRIPTION OF OPERATIONS / LOCATIONS / VEHICLES (Attach ACORD 101, Additional Remarks Schedule, if more space is required)
 YOU MUST LIST THE FOLLOWING AS ADDITIONAL INSURED: SHOW MANAGEMENT; SHOW NAME; FACILITY. THESE ENTITIES MUST BE NAMED AS ADDITIONAL INSUREDS ON A PRIMARY AND NON-CONTRIBUTORY BASIS, EXCEPT FOR WORKERS' COMPENSATION. THE INSURANCE PROVIDED FOR THE BENEFIT OF AGS EXPOSITION SERVICE COMPANY INC SHALL BE PRIMARY INSURANCE IN RESPECT TO ANY CLAIM, LOSS, OR LIABILITY, ARISING OUT OF THE NAMED INSURED'S OPERATIONS FOR WHICH THE NAMED INSURED IS LIABLE. ANY OTHER INSURANCE MAINTAINED BY AGS EXPOSITION SERVICE COMPANY INC SHALL BE EXCESS AND NON-CONTRIBUTORY. THE SHOW DATES ARE: MONTH, DAY (S), YEAR AND IN CITY, STATE. ****EXHIBITING COMPANY NAME**** **4.**

CERTIFICATE HOLDER 5. AGS EXPOSITION SERVICE COMPANY INC 4561 SW 34TH STREET ORLANDO, FL 32811	CANCELLATION SHOULD ANY OF THE ABOVE DESCRIBED POLICIES BE CANCELLED BEFORE THE EXPIRATION DATE THEREOF, NOTICE WILL BE DELIVERED IN ACCORDANCE WITH THE POLICY PROVISIONS. AUTHORIZED REPRESENTATIVE IMA YUR BROKER, CAF, CIC 9. X Signature
--	---

ACORD 25 (2010/05) © 1988-2010 ACORD CORPORATION. All rights reserved.
 The ACORD name and logo are registered marks of ACORD

1. **PRODUCER:** Insurance Agent/Broker who issues certificate.
2. **NAME OF INSURED:** This must be the legal name of the contracting party.
3. **TYPES OF INSURANCE:** This must include all types required by contract. See the "Official Service Contractors and Exhibitor Appointed Contractors form in this Event Services Manual. General Liability and Umbrella Liability must be "OCCURENCE" type.
4. **NAME OF ADDITIONAL INSUREDS:** In this area, you must list Show Management (by name), the Show itself (by name), and the facility (by name) as additional insureds on a primary and non-contributory basis.
5. **CERTIFICATE HOLDER:** AGS Expo Services, Inc. (AGS) MUST be listed as the certificate holder.
6. **POLICY EFFECTIVE DATE:** This date must be prior to or coincidental with the first day of Exhibitor Move-In.
7. **POLICY EXPIRATION DATE:** This date must be on or after the last day of Exhibitor Move-Out.
8. **Limits:** The monetary limits must be the same or greater than what is required by contract. See the "Official Service Contractors and Exhibitor Appointed Contractors" form in this Event Services Manual.
9. **AUTHORIZED REPRESENTATIVE:** This form must be signed (not stamped) by an authorized representative of the producer of the certificate.



Company Name		Tel #	Booth Number
Billing Address		Email	
City / State / Zip		Signature	

Standard Carpet

In-line Booth			
Check One	Booth Size	Discount Price	Standard Price
<input type="checkbox"/>	8'x10'	\$286.82	\$394.51
<input type="checkbox"/>	8'x20'	\$552.77	\$760.33
<input type="checkbox"/>	8'x30'	\$888.30	\$1,140.51

Island Booth					
Booth Dimensions		Total Area	Discount Price	Standard Price	Total Price
20x20 Minimum.					
	x	=	\$8.06/sq.ft.	\$9.38/sq.ft.	\$

• Please note that all carpet is 10 ft wide and is installed accordingly.

Please Choose Your Carpet Color (check appropriate box below):

Blue Red Gray Black Hunter Green Tuxedo Purple Bluejay Teal

Plush Carpet

Enhance your exhibit with 26 oz. plush, heavy-cut polyester pile carpet.

Booth Dimensions		Total Area	Discount Price	Standard Price	Total Price
	x	=	sq.ft. x \$9.91/sq.ft.	\$11.26/sq.ft.	= \$

Please Choose Your Carpet Color (check appropriate box below):

Cherry Red Onyx Black Charcoal Imperial Blue French Beige Emerald Gray Pearl

- Additional colors offered upon request.
- Custom carpet orders must be received by the deadline date above to guarantee carpet selection.
- Plush rental includes installation prior to delivery of your exhibit, taping of all edges, and visqueen covering.

Additional Items

All items are available with standard, custom cut, or plush carpets.

Booth Dimensions		Total Area	Discount Price	Standard Price	Total Price
1/2" Foam Padding	x	=	sq.ft. x \$1.86 /sq.ft.	\$2.42 /sq.ft.	= \$
1" Foam Padding	x	=	sq.ft. x \$3.74 /sq.ft.	\$4.86 /sq.ft.	= \$
Visqueen	x	=	sq.ft. x \$1.46/sq.ft.	\$1.84/sq.ft.	= \$

Please Note:

- All carpet rentals are set clean. However, exhibitor move-in and setup can cause debris. Please order cleaning if necessary.
- Prices include delivery, installation, rental, removal, and are based on exhibit space dimensions.
- To order cleaning services, complete the Booth Cleaning Order Form in the Booth Labor & Cleaning section.
- All utility lines must be installed before carpet installation. Utilities should be ordered in .
- Standard sizes may not completely fill the entire booth space due to placement of utility outlets on the event floor.

Cancellation Policy: Standard Island & Plush booth carpet cancelled after being cut or installed will be charged 100%. Standard in-line carpet and all additional items cancelled will be charged 50% of original price after move-in begins and 100% of original price after installation. All specialty custom flooring orders, including vinyl flooring and custom color requests, will be subject to a 100% cancellation fee if cancelled after the discount deadline.

Total Order

Subtotal: \$ _____
 Sales Tax (7.00%): \$ _____
 Total: \$ _____



Company Name	Tel #	Booth Number
Billing Address	Email	
City / State / Zip	Signature	

Tables

Please use the following form to order any table and table accessories you may need for your booth. All AGS tables are solid wood construction covered with a white vinyl top. You may choose either skirted or unskirted tables.

STEP 1 – Select Table

Skirted Tables			
Qty	Item	Discount	Standard
	4' Table - 30" high	\$228.11	\$296.54
	4' Table - 42" high	\$268.57	\$349.14
	6' Table - 30" high	\$267.14	\$347.31
	6' Table - 42" high	\$306.66	\$398.65
	8' Table - 30" high	\$308.06	\$400.49
	8' Table - 42" high	\$333.94	\$434.12

Unskirted Tables			
Qty	Item	Discount	Standard
	4' Table - 30" high	\$119.47	\$155.30
	4' Table - 42" high	\$158.04	\$205.44
	6' Table - 30" high	\$138.75	\$180.38
	6' Table - 42" high	\$196.60	\$255.97
	8' Table - 30" high	\$163.22	\$212.17
	8' Table - 42" high	\$200.37	\$260.46

Table Accessories

Surround your table with a 4th side skirt covering all sides or place your items and information in clear view of attendees with a table riser.

Table Risers (Draped in White Vinyl)			
Qty	Item	Discount	Standard
	4'L x 8"W x 8"H	\$103.47	\$134.51
	6'L x 8"W x 8"H	\$147.03	\$192.00
	8'L x 8"W x 8"H	\$195.21	\$253.75

4th Side Skirts (Optional - only applicable to 6' and 8' tables)			
Qty	Item	Discount	Standard
	4th Side Skirted 30"h	\$124.18	\$161.42
	4th Side Skirted 42"h	\$124.18	\$161.42

STEP 2 – Select Skirt Color

Blue Teal Hunter Green Red Black Purple White Gray Burgundy Gold

Show color will apply if no color is selected. Color availability is only guaranteed with pre-orders.



Table with Skirt



Table with Riser & Skirt

CANCELLATION POLICY: Table orders cancelled during or after show move in, including change order requests, will receive a 50% refund of original price.

Total Order

Subtotal: \$ _____
 Sales Tax (7.00%): \$ _____
 Total: \$ _____

AGS Expo Services • 4561 SW 34th Street • Orlando, FL 32811
 Phone: 407.292.0025 • Fax: 407.292.4414

Email: eventservices@ags-expo.com Order Online: www.ags-expo.com

TABLE ORDER FORM



Company Name	Tel #	Booth Number
Billing Address	Email	
City / State / Zip	Signature	

Seating & Accessories

Please use the following form to order any seating and accessories you may need for your booth. All AGS accessories have been selected with the exhibitor in mind providing the best in seating and exhibiting accessories to display your products successfully.

Seating			
Qty	Item	Discount	Standard
	Padded Arm Chair	\$192.35	\$252.42
	Padded Side Chair	\$158.41	\$231.83
	Padded Stool	\$231.14	\$278.84
	Plastic Folding Chair	\$116.31	\$145.39

Specialty Tables			
Qty	Item	Discount	Standard
	Pedestal Table 30"Dx30"H	\$317.99	\$413.37
	Pedestal Table 30"Dx40"H	\$317.99	\$413.37

Display Items			
Qty	Item	Discount	Standard
	Display Case (6'x36" full view)	\$1,214.93	\$1,579.41
	Vert. Display Case (6' - 5 shelf)	\$1,316.47	\$1,711.44
	Ticket Tumbler	\$156.77	\$203.80
	Tack Board (vert. or hori.)	\$525.53	\$683.19
	Grid Panel (per meter)	\$293.94	\$382.14
	Chrome Sign Holder 22"x28"	\$186.16	\$242.09
	Easel	\$81.94	\$106.54
	Literature Rack	\$217.35	\$282.66
	Bag Rack	\$217.35	\$282.66
	Garment Rack	\$170.14	\$221.17
	Clothes Tree	\$170.14	\$221.17
	Fishbowl	\$32.07	\$41.68

Booth Basics			
Qty	Item	Discount	Standard
	Wastebasket	\$42.37	\$55.09
	Booth Close-off Drape (Show Color)	\$81.46	\$111.46
	Shrink Wrap (per roll)	N/A	\$116.31
	Banding (per foot)	N/A	\$5.36
	Velcro (per foot)	N/A	\$3.12
	Clear Packing Tape (roll)	N/A	\$31.28

Specialty Drape <i>(Show Management approval required)</i>			
Qty	Item	Discount	Standard
	Drape Hardware - Bases	\$20.50	\$26.64
	Drape Hardware - Uprights	\$20.50	\$26.64
	Drape Hardware - Crossbars	\$20.50	\$26.64
	8' Drape (per foot, 10' min per order)	\$18.73	\$24.88
	3' Drape (per foot, 10' min per order)	\$12.99	\$19.73

Specialty Items			
Qty	Item	Discount	Standard
	Chrome Stanchion	\$99.76	\$129.69
	Black Velour Rope (8' sections)	\$71.25	\$92.65
	Belt Barriers	\$198.03	\$247.98

Specialty Drape Color:			
Blue	Teal	Hunter Green	Red
Black	Purple	White	Gray
Burgundy	Gold		

CANCELLATION POLICY: Seating & accessory orders cancelled during or after show move in, including change order requests, will receive a 50% refund of original price.

Total Order

Subtotal: \$ _____

Sales Tax (7.00%): \$ _____

Total: \$ _____

AGS Expo Services • 4561 SW 34th Street • Orlando, FL 32811
 Phone: 407.292.0025 • Fax: 407.292.4414

Email: eventservices@ags-expo.com Order Online: www.ags-expo.com

EXHIBIT RENTALS

ORDERING YOUR NEXT INNOVATIVE DISPLAY RENTAL IS EASY AS 1-2-3!

1 CONNECT WITH YOUR EXHIBIT SPECIALIST

- Email: exhibits@ags-expo.com
- Call: 407-292-6162

2 ONE-ON-ONE CONSULTATION

- Designs to maximize your ROI
- Experienced client consultation to express your vision



3 CREATE THE BOOTH OF YOUR DREAMS

- Free design options in 48 hours
- No hidden fees - transparent pricing
- Turn-key packages on your budget



DOWNLOAD
OUR NEWEST DESIGNS

READY?

LET'S DO THIS TOGETHER!

exhibits@ags-expo.com | 407-292-6162

No
Material Handling
On Rentals

Free
Display
Shipping

AGS
DOLLARS
& SENSE



Company Name	Tel #	Booth Number
Billing Address	Email	
City / State / Zip	Signature	

Labor Install/Dismantle

Labor Rates		Discount	Standard
Straight-Time:	8:00 AM to 4:30 PM Monday through Friday.	\$138.01	\$179.45
Overtime:	Before 8:00 AM and after 4:30 PM Monday through Friday and all day on Saturday.	\$207.05	\$269.38
Double-Time:	All day Sunday and observed Holidays where applicable.	\$276.09	\$358.81

• Each Additional Laborer: Standard labor rates apply for additional laborers added to the order.

Calculate Labor	Date	Time	# of Laborers	Total Hours	Rate per Laborer	Total Cost
Installation		AM / PM			\$	\$
Dismantle		AM / PM			\$	\$
(Example calculation - 2 Laborers x 2 Hours x Rate/Laborer = Total Cost)				Total Labor Cost:	\$	\$

- After the 1st hour time can be billed in 1/2 hour increments.

Supervision of Labor

Supervision of all labor is required. Please select a supervision plan by checking the boxes.

AGS Supervision Install Dismantle

All labor performed under the supervision of AGS. Our fee for installation supervision is 35% or a \$50.00 minimum, whichever is greater. Similarly, our fee for dismantle supervision is 35% or a \$50.00 minimum, whichever is greater. In order to perform the labor without exhibitor's representative present, **AGS MUST have detailed set-up instructions (blueprints/floorplans, etc.) with this labor order.**

Exhibitor must also include outbound shipping instructions with this labor order.

(SEE OUTBOUND BOL/SHIPPING LABEL REQUEST FORM)

On-Site Representative Name/Company & Cell: _____

Exhibitor Supervision Install Dismantle

All labor performed under the supervision of exhibitor. Starting time guaranteed only in those instances where labor is requested for the start of the work day (e.g. 8:00 AM). **Exhibitor MUST check-in at the AGS Service Center to confirm labor order and check-out labor at the AGS Service Center upon completion of work.**

Must provide Twenty-four (24) hour notice of cancellation of labor services. Without twenty-four (24) hour notice, exhibitor will be charged a one hour minimum per laborer ordered.

Total Order

Total Labor Cost (from Total Labor Cost above) Subtotal: \$ _____

AGS Supervision Fee (per supervision service, 35% or \$50.00 min.): \$ _____

Sales Tax (7.00%): \$ _____

Total Booth Labor: \$ _____



Company Name	Tel #	Booth Number
Billing Address	Email	
City / State / Zip	Signature	

Outbound Bill of Lading/Shipping Label Request

All outbound shipments require an Official AGS Bill of Lading and shipping labels. AGS Expo Services offers complimentary pre-printing of these items. To take advantage of this service, please complete this request and submit to AGS. You must submit a valid and complete method of payment form with this form to receive this service.

Showsite Instructions:

- **Completed BOL must be turned in to the AGS Service Center prior to your departure.**
- AGS will print and deliver your BOL with shipping labels to your booth prior to the close of the show.
- Exhibitors must properly package and label all materials.
- Shipments without paperwork will be considered abandoned and will be re-routed via the show carrier at the Exhibitor's expense. AGS does not accept responsibility for any exhibitor property left on the show floor unattended at any time for any reason.

Ship to Address:

Company: _____
 Address: _____
 City: _____ State: _____ Zip: _____
 Attention/Show/Booth #: _____

Number of Destinations: _____ Number of pieces: _____ Number of Labels Requested: _____

- **If you have more than (1) destination please fill out a form for each individual destination.**
- **Please indicate your piece count by type below.**

_____ Crate (Wood) _____ Skid (Pallet) _____ Cases (Plastic) _____ Carton (Cardboard) _____ Anvil Case/Trunks _____ Other (Bundles, pad wraps, etc)

Select Shipping Method:

- Ship via official show freight carrier, **ABF Freight**
 Ship via carrier of exhibitor's choice - Name of Carrier _____
 • If selecting a carrier other than ABF Freight, you must schedule the pickup.

****In the case that your carrier does not show please select one of the below dispositions for your shipment****

Re-Route via Show Carrier, ABF Freight

Drayback to Warehouse - A minimum fee of \$850.00 will be charged. *Fee may be greater. See Material Handling Info & Rates form for full terms of service

Is this shipment Prepaid or Collect (Please select one):

*Exhibitors are responsible for settling all transportation costs with the carrier of their choosing directly.

Prepaid By selecting Prepaid, you are indicating that material for shipment will be paid by the sender (you)

Collect By selecting Collect, you are indicating that the receiving party will be responsible for payment upon receipt of the materials

Bill Shipping Charges to (if different from ship to address):

Shipper (Print): _____ Email: _____
 Contact Name: _____ Cell: _____
 Freight Charges Billed to (Company): _____
 Address: _____
 City: _____ State: _____ Zip: _____



Company Name	Tel #	Booth Number
Billing Address	Email	
City / State / Zip	Signature	

Booth Cleaning Order Form

The form below offers a variety of services including vacuuming, trash removal, and other cleaning services that will give your booth the clean look you desire. If your booth requires a cleaning service that is not listed, please contact us and we will be more than happy to assist in organizing the services you require.

Please Indicate Booth Area

BOOTH SIZE - _____ X _____ = _____ (sq. ft. round up to the nearest 100 sq. ft.)
--

- Cost of vacuuming and other area related services will be invoiced based on **100 sq. ft. minimum** and/or total square footage rounded up to the nearest 100 sq. ft.

Vacuuming Service *(Includes trash removal at the end of each event day)*

This service includes vacuuming of carpet and exhibit space.

- Vacuuming Nightly \$0.91/sq. ft.* Vacuuming Once Before Event \$0.99/sq. ft.

**Please calculate for (3) event days.*

Periodic Porter Service

This service includes periodic trash removal during exhibit hours to keep your booth fresh.

This service only takes place during show hours and does not include vacuuming services.

- Periodic Porter Service - Daily .. \$179.40/day** Day-Specific Porter Service \$203.81/day

***Please calculate for (3) event days.*

(Please indicate days) _____

- Complete Porter Service** *(Call to arrange service)*

This service includes the removal of trash, cleaning of surfaces, ice removal, and other similar labor services. **Quoted as needed.*****

- **Straight-Time:** \$100.65/hr . 8:00 AM - 4:30 PM, Monday through Friday.
 - **Overtime:** \$120.76/hr . 4:30 PM - 8:00 AM, Monday through Friday and all day Saturday.
 - **Double-Time:** \$143.54/hr . all day Sunday and observed Holidays, where applicable.
- ***One (1) Hour Minimum for all service calls.*

Other Cleaning Services

- Shampooing of Carpet* \$1.41/sq. ft.
 Mopping and Waxing*..... \$1.41/sq. ft.
 Anti-Static Carpet Treatment.... \$0.50/sq. ft

*Shampooing and mopping available before show opens **ONLY**

**Cancellation requests received within twenty-four (24) hours of service will be subject to a 100% cancellation fee*

Total Order

Total Sq. Ft.

X

Vacuuming: \$0.91/sq. ft. or \$0.99/sq. ft. x _____ Days = \$ _____
Shampooing/Mopping: \$1.41/sq. ft. x _____ Days = \$ _____
Anti-Static Treatment: \$0.50/sq. ft. x _____ Days = \$ _____
Porter Service: \$203.81 or \$179.40/day x _____ Days = \$ _____

Tax (7.00%): \$ _____

Total Booth Cleaning Order: \$ _____

BEFORE THE EVENT

From your location or previous event



To your location or next event

AFTER THE EVENT

Storage of Empty Containers



Advance Warehouse

Where your materials are stored before the show



Storage of Empty Containers

Holding your crates/boxes/containers for you during the show



Premium Return Service Available

Labeling your empty containers for priority return to your booth at the end of the show for a speedy exit. Service fee will apply. Contact Event Services for more information.



Material Handling

Round trip service includes receiving materials at the dock area, delivering to your booth, storage of empty containers during the event, movement of materials back to the dock and on loading your carrier.



2026 FCCFA Annual Convention
& Trade Show
JW Marriott Turnberry
Miami, FL
July 23 - 25, 2026

Discount Price
Deadline Date
JULY 9th

Method of payment must accompany your order



Material Handling Information & Rates

The following information has been compiled by AGS for use by exhibitors and all third-party contractors to inform you of rates and rules regarding proper shipping and handling to and from your event. If you require more information regarding specific services or have issues regarding material handling at your event, please call our Event Services Department or contact us via email at eventservices@ags-expo.com

SHIPPING INFORMATION

Shipment Pick-ups & Deliveries

Drivers will be required to record their shipments at the Exhibit Site Check-In Area and then they will be directed to the proper freight door for loading and unloading. This includes access to any POV ramps.

Material Handling Order Form

Please make sure to submit your Material Handling Order Form to AGS. This will ensure the proper handling of exhibit materials.

All shipments delivered to either the exhibit site require a delivery slip showing the number of pieces, weight, and type of merchandise. Surcharges apply to all shipments that arrive without proper piece-count and/or weight ticket information. This includes bulk consignment carriers such as FedEx and UPS Package.

Drivers will be required to submit a CERTIFIED WEIGHT TICKET when recording their shipment at the Exhibit Site Check-In Area. AGS Expo Services reserves the right to refuse such shipments until a certified weight ticket is presented.

NOTE: Shipments received without receipts, freight bills, or specified unit counts on receipts or freight bills (e.g. one lot, 800 cu. ft., etc.) from carriers such as FedEx or UPS Package, will be delivered to the exhibitor's booth without guarantee of piece-count or condition. No liability will be assumed by AGS Expo Services for such shipments. In the event no weight is indicated on the documents presented, AGS Expo Services shall estimate the weight and charges will be based on the estimate. These charges will not be subject to adjustment.

Please ensure that copies of all shipping information are sent to the person or company in charge of installing your display. This will assist in locating any packages that are missing or fail to arrive.

Insurance

Be sure your materials are insured from the time they leave your company until they are returned after the event. It is suggested that exhibitors arrange all-risk coverage. This can usually be done by adding riders to existing policies. Each event is different. As a result, certain facilities provide different levels of security for exhibitors and their materials. In most cases, security is arranged by the association or event management but is not always available during certain times of the event. Please take every precaution to secure items in your booth. During move-out, never leave packed materials in your booth unsupervised. AGS always requires exhibitor supervision of outbound packages to ensure their safe transfer.

Basic Tips for Shipping

- Securely pack all items for shipping and remove old shipping labels.
- Fill out and apply shipping labels with appropriate address, company name, booth number, and consign all shipments c/o AGS Expo Services.
- Send your Material Handling Order Form to AGS to ensure their arrival.
- Check with AGS as to the receipt of your shipped packages.
- All shipments must have a bill of lading or delivery slip indicating the number of pieces and weight.
- Certified weight tickets must accompany all shipments.



2026 FCCFA Annual Convention
& Trade Show
JW Marriott Turnberry
Miami, FL
July 23 - 25, 2026

Discount Price
Deadline Date
JULY 9th

Method of payment must accompany your order



Material Handling Information & Rates

Shipping Labels

All packages must be clearly labeled with the appropriate address, booth number, and consignment information. Please remember to remove all old labels from your shipping containers as this will ensure that there is no confusion over booth number, addresses, or other erroneous information not related to this specific event.

Crates & Material Packaging

Ensure that your containers are properly maintained or replaced to prevent the damage of any internal items during shipping and handling. Please understand that all containers associated with shipping are considered protection and are therefore not covered if damaged during shipping and handling. These containers are designed to take external forces in order to protect their internal contents.

Rate Classification

Off-Target Charges on Direct Shipments

Shipments unloaded prior to Direct Receiving for exhibitor move-in will be subject to a 30% off-target service charge based on the Direct Shipment Rate (which ever applies), for each 100 lbs. or fraction thereof per shipment, unless the shipment was handled by the official carrier. Charges for off-target delivery methods may also apply. Such off-target shipments cannot be guaranteed advance delivery to the show site.

Direct Shipments to Exhibit Site - Services & Rates

Shipments for direct delivery to the exhibit site should be scheduled to arrive by the date and times set forth in the Shipping Information section of this Exhibitor Service Manual. These shipments should be consigned to AGS Expo Services c/o JW Marriott Turnberry and labeled with appropriate show name and booth number. Materials will be unloaded from exhibitor's trucks or trucks of other carriers at the exhibit site; delivered to the exhibitor's booth; storage of empty containers during the event; picked-up at the close of the event; moved to the loading area; and reloaded on trucks. **The ROUND TRIP RATE of \$159.58 applies for each 100 lbs. or fraction thereof per shipment with a 200 lb. minimum per shipment.**

Overtime Surcharges at Exhibit Site

Overtime charges on inbound shipments will be in effect if:

- A vehicle checks-in or is unloaded at the Exhibit Site Check-In Area after 4:30 PM on weekdays or anytime on Saturday/Sunday/Holidays.

Overtime charges on outbound shipments will be in effect if:

1. Your shipment is loaded after 4:30 PM on the day the exhibit closes.
2. Your carrier checks-in at the Exhibit Site Check-In Area after 4:30 PM on weekdays or anytime on Saturday/Sunday/Holidays.
3. Additionally, when freight must be moved out of the exhibit site on overtime due to scheduling conflict beyond the control of AGS Expo Services, overtime charges will be applied. An overtime surcharge based on the exhibit site rates for each 100 lbs. or fraction thereof per shipment will be invoiced in addition to those rates on all shipments.

Overtime charges at the exhibit site subject to overtime rates:

- For each 100 lbs. or fraction thereof per shipment, the rate is **\$47.87** with a **200 lb. minimum**.

Special Handling - Shipments or Equipment Requiring Special Handling



2026 FCCFA Annual Convention
& Trade Show
JW Marriott Turnberry
Miami, FL
July 23 - 25, 2026

Discount Price
Deadline Date
JULY 9th

Method of payment must accompany your order



Material Handling Information & Rates

This classification applies to, but is not limited to, moving van shipments or shipments by any trucks which, because of their truck bed height, cannot be unloaded at the docks and/or the shipment is packed in such a manner as to require special handling (i.e. loose display parts, uncrated equipment, etc.) regardless of the kind of carrier or vehicle used and/or the description of the shipment is such that the type of materials or equipment cannot be determined (e.g. 1 lot; many assorted pieces, etc.). This also includes shipments delivered by carriers such as FedEx, UPS Package, and other parcel style carriers with bulk consignment.

Materials will be unloaded from moving vans, exhibitor's truck, or trucks of other carriers at the exhibit site; delivered to the exhibitor's booth; stored as empty containers during the event; picked-up at the close of event; moved to the loading area; and reloaded on trucks.

The rate of **\$239.36** applies for each 100 lbs. or fraction thereof per shipment with a **200 lb. minimum per shipment**.

NOTE: In the event crated materials are combined in a shipment with materials packed in such a manner as to require special handling (see above), AGS Expo Services will invoice such shipments at the rates applicable to the classification of the materials, PROVIDED the Bill of Lading clearly identifies the weight of the crated materials and the weight of the other materials. If the Bill of Lading does NOT identify the weights of the various classifications, the entire shipment will be invoiced at the Special Handling Rate and will not be subject to adjustment.

Small Package Rates

Small Package Rates ONLY apply to direct deliveries to the exhibit site and should be scheduled to arrive on the dates and times set forth in the Shipping Information section of this Exhibitor Service Manual. These shipments should be consigned to AGS Expo Services c/o JW Marriott Turnberry and labeled with appropriate show name, company name, and booth number. Such items considered small packages are cartons, envelopes, and other non-crated items that have a maximum weight of 30 lbs. per shipment, per delivery, per day, by the same carrier. This includes FedEx and UPS Package shipments. Materials will be unloaded from the dock or trucks at the exhibit site and delivered to the exhibitor's booth. **This INBOUND ONLY RATE applies to small packages with a total shipment weight of 30 lbs. or a fraction thereof where the first piece is \$68.00 and each subsequent piece is \$38.00. If the total weight of the shipment exceeds 30 lbs, the shipment will be subject to standard Material Handling service fees, or that which applies, depending upon time of arrival and other policies surrounding its receipt (i.e. special handling). A 15% surcharge may be applied on all items delivered without documentation or by carriers such as FedEx, UPS Package, and other parcel style carriers with bulk consignment.**

Premium Return Services

AGS offers Premium Return Service for material handling storage at this event. This service includes all classifications of material handling storage listed in this Material Handling Information & Rates section. This service will provide priority return of stored materials at the close of the event. All materials labeled for Premium Return Service will be guaranteed first return. This service has limited availability and is based on storage capacity of the event venue. This is not an alternative to material handling. Material handling services must be established prior to ordering this service.

Outgoing Shipments

To assist you in setting-up your outgoing shipments, AGS Expo Services will have a shipping desk located at the AGS Service Center where labels, Bills of Lading and shipping information will be available.

Freight Re-Route Policy

At the close of the show, if carriers fail to pick-up or refuse to accept shipments, or no disposition is provided by the exhibitor, AGS Expo Services reserves the right to either re-route such shipments or materials via the Official Show Carrier, or dray back to the warehouse and await instructions from the exhibitor. **If the shipment is drayed back to the**

Freight Re-Route Policy Cont...

warehouse, there will be a Service Fee minimum of \$850.00 for transportation and/or storage. Drayback fees are based on conditions at the time of service and will range from \$850 to \$2,500. Please note that these fees cover the

AGS Expo Services • 4561 SW 34th Street • Orlando, FL 32811
Phone: 407.292.0025 • Fax: 407.292.4414

Email: eventservices@ags-expo.com Order Online: www.ags-expo.com



2026 FCCFA Annual Convention
& Trade Show
JW Marriott Turnberry
Miami, FL
July 23 - 25, 2026

**Discount Price
Deadline Date
JULY 9th**

Method of payment must accompany your order



Material Handling Information & Rates

movement of your materials from the event to the local warehouse only and do not include any final shipping or handling charges. AGS is not responsible for the assignment of fees or charges made by the carrier in association with freight re-routes or dray backs. No liability will be assumed as a result of such re-routing or handling. **Post-show disposal of all empty crates, carpeting or display materials are the responsibility of the exhibitor including disposition or return to company warehouse.** Any of the before mentioned items abandoned by exhibitors will be assessed a Service Fee beginning at \$500, depending on size and weight. This service fee will be charged by AGS in addition to any fees applied by the Convention Center or Official Show Carrier for crate removal.

MATERIAL HANDLING & RATES

AGS Expo Services • 4561 SW 34th Street • Orlando, FL 32811
Phone: 407.292.0025 • Fax: 407.292.4414

Email: eventservices@ags-expo.com Order Online: www.ags-expo.com

Special Handling Definitions

What is "Special" Handling?

Special Handling applies to shipments that are loaded in such a manner as to require additional labor and handling to unload or load out. An additional fee beyond the standard crated rate will apply. Shipments loaded in this manner require additional time, labor, or equipment to unload, sort, and deliver.

Special Handling Includes:

Ground Loading

- Vehicles that are not dock height, preventing the use of loading docks

Side Door Loading

- Shipments tendered for delivery in such a manner as to prevent access from the rear of the trailer.

Constricted Space Loading

- Freight loaded "high and tight" or down one side as to make shipments not readily available.

Designated Piece Loading

- When a trailer must be loaded in a particular sequence to ensure fit.

Stacked, Cubed-Out, or Loose Shipments

- Shipments loaded in such a manner requiring items to be removed to ground level for delivery to booth.
- Items that would need to be unstacked/stacked, unstrapped/strapped, or loadbars to be removed/installed during the unload or load out process.

Mixed Shipments

- Pieces for separate shipments that are loaded mixed throughout the delivery vehicle, or shipments of crated and uncrated goods where the percentage of uncrated is minimal and does not warrant full uncrated rate for shipment.

Improper Delivery Receipts

- Shipments that arrive without individual Bill of Lading. Possible examples might include: UPS, FedEx, company trucks, privately-owned vehicles.

Uncrated Shipments

- Material that is shipped loose or pad-wrapped, and/or unskidded machinery without proper lifting bars or hooks.

Improper Weight

- Shipments that come in and are re-weighed showing the documentation was incorrect with a lower weight than the actual weight. These shipments get charged special handling plus a weight ticket charge.



Side Door Loading



Constricted Space Loading



Stacked Shipments



Uncrated Shipments



Multiple Shipments



2026 FCCFA Annual Convention
& Trade Show
JW Marriott Turnberry
Miami, FL
July 23 - 25, 2026

**Discount Price
Deadline Date
JULY 9th**
Method of payment must accompany your order



Reducing Material Handling Costs

To reduce material handling costs related to labor, we recommend sending your goods all together in one shipment. For each 100 lbs. or fraction thereof per shipment, AGS sets a graduated flat rate with a 200 lb. minimum. It is important to carefully read the Material Handling section of this Exhibitor Service Manual. This section also outlines the overtime and forced freight policies.

TIPS FOR SENDING TO:

THE SHOW SITE

- When sending shipments direct to show site, ensure that each package has its packing slip or shipping bill indicating the number of pieces and weight. To ensure the accuracy of material handling charges, AGS may weigh shipments as they arrive and compare the results to the Bill of Lading. A weight ticket will be attached to the receiving paperwork for any shipments that are adjusted. On-site weighing may be accepted as actual weight or shipments may be refused without a certified weight ticket. In such cases where on-site weighing is necessary, you may be assessed a fee for this service.
- Items that arrive before the scheduled move-in times or during the show will be assessed an off-target fee or may fail to be accepted.
- Many times shipments arrive piecemeal and require sorting. To avoid sorting fees related to bulk consignment carriers, try to send shipments together and avoid package carriers such as FedEx and UPS Package.

Here are some common mistakes that can result in higher material handling charges:

- Multiple small shipments arriving separately - There is a 200 pound minimum per shipment over 30 lbs. (On-site only)
- Missing your target date - If there is no way to avoid missing your target date, contact AGS.
- No certified weight ticket accompanying your shipments.

EXAMPLE OF SAVINGS

Received - *Multiple Shipments*

51 lbs.	charged @ \$159.58 per cwt. 200 lbs. min. = \$319.16	
43 lbs.	charged @ \$159.58 per cwt. 200 lbs. min. = \$319.16	
64 lbs.	charged @ \$159.58 per cwt. 200 lbs. min. = \$319.16	TOTAL = \$957.48

Received - *Single Shipment*

(3 pcs) 158 lbs.	charged @ \$159.58 per cwt. 200 lbs. min. = \$319.16	TOTAL = \$319.16
------------------	--	-------------------------

REDUCING MATERIAL HANDLING COSTS

SAVE \$638.32

AGS Expo Services • 4561 SW 34th Street • Orlando, FL 32811
Phone: 407.292.0025 • Fax: 407.292.4414

Email: eventservices@ags-expo.com Order Online: www.ags-expo.com



2026 FCCFA Annual Convention
& Trade Show
JW Marriott Turnberry
Miami, FL
July 23 - 25, 2026

**Discount Price
Deadline Date
JULY 9th**
Method of payment must accompany your order



Freight Re-Route Policy

AGS wants to ensure that your materials reach their intended destination. Therefore, any unconsigned shipments left in the exhibit hall after dismantling hours will be shipped via the official show carrier at the expense of the exhibitor. Please read the important information below to help avoid having your freight re-routed.

Driver Check-in: Saturday, July 25th by 1:00 PM
Freight Re-Route Time: Saturday, July 25th at 1:01 PM

What is Freight Re-Route?

A “re-route” occurs when a carrier does not check-in or show up at the dock for the consigned freight. We want to make sure each exhibitor gets their first choice of a carrier and therefore no freight is re-routed until we must move it to complete the contracted move-out agreement between show management, the convention center, and AGS Expo Services.

Bill of Lading

Each exhibitor is responsible for turning in an AGS Bill of Lading to the AGS Service Center after dismantling is finished and all boxes/crates/materials are packed and labeled. The Bill of Lading is the official “permission” by the exhibitor to allow the removal of freight from the booth to the carrier of choice (personal vehicle, truck, van line, air freight, etc.).

Official Show Carrier

The official show carrier is on-site as a convenience to exhibitors, and to service show management, and is by no means the only choice available. Exhibitors are welcome to use either the official carrier or an Exhibitor Appointed Carrier. Rates may be negotiated in advance by calling the official show carrier.

Other Carriers

If freight is consigned to a service carrier other than the official show carrier, that carrier must check-in with the loading dock by the time specified above. Show management, AGS Expo Services, and the official show carrier cannot be responsible for checking with all designated carriers. If you have chosen a carrier other than the official show carrier, **we require that someone from your company remain with the shipment until it is picked-up.** Many times, a reminder phone call to your carrier will ensure the official time window is adhered to and your freight is picked up successfully.

Freight Re-Route Contact

In the event that your freight is re-routed by AGS, please contact our Event Services Department during regular business hours Monday through Friday from 8:00 am – 5:00 pm at 407.292.0025 to obtain tracking and destination information.



TO: AGS Expo Services
c/o JW Marriott Miami Turnberry Resort & Spa
King Ballroom
1999 West Country Club Drive
Adventura, FL 33180

2026 FCCFA Annual Convention & Trade Show

COMPANY NAME: _____

BOOTH NUMBER: _____

MUST BE DELIVERED:
Thursday, July 23, 2026 - 1:00 PM - 6:00 PM

DIRECT SHIPPING LABEL

✂ PLEASE CUT ALONG THIS LINE AND AFFIX LABEL TO PACKAGE ✂
PLEASE MAKE ADDITIONAL COPIES OF THESE LABELS AS NEEDED



TO: AGS Expo Services
c/o JW Marriott Miami Turnberry Resort & Spa
King Ballroom
1999 West Country Club Drive
Adventura, FL 33180

2026 FCCFA Annual Convention & Trade Show

COMPANY NAME: _____

BOOTH NUMBER: _____

MUST BE DELIVERED:
Thursday, July 23, 2026 - 1:00 PM - 6:00 PM

DIRECT SHIPPING LABEL



Company Name	Tel #	Booth Number
Billing Address	Email	
City / State / Zip	Signature	

Material Handling Estimate Form

Please use this form to indicate how much incoming freight AGS can expect from your company. We understand that your calculation is only an estimate and adjustments will be made according to the actual weight listed on the inbound Bills of Lading. If you have any questions about material handling, please refer to the forms in this Exhibitor Service Manual titled "Shipping Instructions and Material Handling."

MATERIAL HANDLING RATES (DEADLINE DATES)

Direct to Show Site - (7/23/26)

- \$159.58 per 100 lbs, 200 lbs min. per shipment

Special Handling at Show Site - (7/23/26)

- \$239.36 per 100 lbs, 200 lbs min. per shipment

Small Packages - <30 lbs - (Show Site Only)

- \$68.00 1st Carton, \$38.00 each add., per shipment

Please note:

- When recording weight, round-up to the next 100 lbs. Example: 235 lbs. = 300 lbs., 3 x Material Handling Rate per 100 lbs.
- **A 30% Overtime Surcharge will be applied for any mandatory weekend and/or after 4:30 PM move-in / move-out.**

Direct Shipments to Show Site

We will ship.... _____ lbs. @ \$159.58 per 100 lbs. (200 lbs. min, \$319.16 Minimum per shipment)

Total Weight _____ lbs. x \$ _____ rate per 100 lbs.= \$ _____

- *Materials received prior to move-in date/time will be assessed an off-target charge or may be refused by the facility.*

Special Handling at Show Site

Special handling applies to items such as machinery or equipment, specially packaged or otherwise, requiring the use of a specialized forklift or excess labor to organize such items and move them from the dock.

We will ship.... _____ lbs. @ \$239.36 per 100 lbs. (200 lbs. min, \$478.72 Minimum per shipment)

Total Weight _____ lbs. x \$ _____ rate per 100 lbs.= \$ _____

Small Packages at Show Site ONLY

We will ship.... _____ Packages @ \$68.00 for the first package and \$38.00 for each additional package contained in the same shipment

Total Number of Packages _____ x \$68.00 / \$38.00 = \$ _____

Total Order

Material Handling Services - Subtotal: \$ _____

30% Overtime Surcharge (Subtotal x 30%): \$ _____

Sales Tax (7.00%): \$ _____

Total Material Handling Cost: \$ _____



Company Name	Tel #	Booth Number
Billing Address	Email	
City / State / Zip	Signature	

Outbound Bill of Lading/Shipping Label Request

All outbound shipments require an Official AGS Bill of Lading and shipping labels. AGS Expo Services offers complimentary pre-printing of these items. To take advantage of this service, please complete this request and submit to AGS. You must submit a valid and complete method of payment form with this form to receive this service.

Showsite Instructions:

- **Completed BOL must be turned in to the AGS Service Center prior to your departure.**
- AGS will print and deliver your BOL with shipping labels to your booth prior to the close of the show.
- Exhibitors must properly package and label all materials.
- Shipments without paperwork will be considered abandoned and will be re-routed via the show carrier at the Exhibitor's expense. AGS does not accept responsibility for any exhibitor property left on the show floor unattended at any time for any reason.

Ship to Address:

Company: _____
 Address: _____
 City: _____ State: _____ Zip: _____
 Attention/Show/Booth #: _____

Number of Destinations: _____ Number of pieces: _____ Number of Labels Requested: _____

- **If you have more than (1) destination please fill out a form for each individual destination.**
- **Please indicate your piece count by type below.**

_____ Crate (Wood) _____ Skid (Pallet) _____ Cases (Plastic) _____ Carton (Cardboard) _____ Anvil Case/Trunks _____ Other (Bundles, pad wraps, etc)

Select Shipping Method:

- Ship via official show freight carrier, **ABF Freight**
 Ship via carrier of exhibitor's choice - Name of Carrier _____
 • If selecting a carrier other than ABF Freight, you must schedule the pickup.

****In the case that your carrier does not show please select one of the below dispositions for your shipment****

Re-Route via Show Carrier, ABF Freight

Drayback to Warehouse - A minimum fee of \$850.00 will be charged. *Fee may be greater. See Material Handling Info & Rates form for full terms of service

Is this shipment Prepaid or Collect (Please select one):

*Exhibitors are responsible for settling all transportation costs with the carrier of their choosing directly.

Prepaid By selecting Prepaid, you are indicating that material for shipment will be paid by the sender (you)

Collect By selecting Collect, you are indicating that the receiving party will be responsible for payment upon receipt of the materials

Bill Shipping Charges to (if different from ship to address):

Shipper (Print): _____ Email: _____
 Contact Name: _____ Cell: _____
 Freight Charges Billed to (Company): _____
 Address: _____
 City: _____ State: _____ Zip: _____



Company Name	Tel #	Booth Number
Billing Address	Email	
City / State / Zip	Signature	

Cartload Service Order Form

AGS will provide cartload service for your event during exhibitor move-in and move-out, with equipment and personnel available to assist.

Availability of Service

Move-In:

Thursday, July 23, 2026 - 1:00 PM - 6:00 PM

Move-Out:

Saturday, July 25, 2026 - 12:00 PM - 2:00 PM

Scheduling Cartload Services

- Cartload service is available only during move-in and move-out.
- Pre-ordered services will have priority access to the loading dock and labor. On-site requests are first-come, first-served.
- All exhibitors must check in at the loading dock, and vehicles must be removed immediately after unloading.**

Limits of Services

- Applicable only to Privately Owned Vehicles (POVs) such as cars, pickup trucks, passenger vans, etc.
- Maximum weight for cartload service is 199 lbs. Limit two cartloads per exhibitor for move-in and two for move-out.
- Over 199 lbs. in total will incur material handling charges.**

VEHICLES THAT QUALIFY:



Sedan



SUV



Pickup



Van

VEHICLES THAT DO NOT QUALIFY:



Trailer



Rentals



Bobtail



Stakebed

Rates

This service includes the loading/unloading of materials to/from POVs ONLY, delivery and unloading to a single location at the exhibit site or handling to the loading area and reloading on outbound POVs.

The ONE WAY RATE for each cartload is \$196.67.

- PLEASE COMPLETE THE FORM BELOW AND SUBMIT WITH YOUR METHOD OF PAYMENT -

Date	# of Cartloads	Cartload Rate	Estimated Cost
Example mm-dd-yy	1	\$196.67	\$196.67
Sales Tax (7.00%):			\$
Total Cartload Service Order:			\$



2026 FCCFA Annual Convention
& Trade Show
JW Marriott Turnberry
Miami, FL
July 23 - 25, 2026

Discount Price
Deadline Date
JULY 9th

Method of payment must accompany your order



Terms & Conditions of Contract - Material Handling Services

Acceptance. By accepting any goods and/or services (“Services”) provided by AGS Exposition Services, Inc. (“AGS”) and/or its carriers, contractors, and each of their agents (collectively, the “AGS Parties”), the Customer and any other party with an interest in, or who benefits from, such goods or Services agree to be bound by these Terms and Conditions (this “Agreement”).

Changes. AGS may modify these Terms and Conditions in its sole discretion upon advance notice to affected parties.

1. Scope; Binding Effect

These Terms bind AGS, Customer, and their respective agents and representatives, as well as any shipper, consignee, customer-contracted labor (including installation and dismantle companies and personnel), and any other party with an interest in or benefiting from the Services. Each such party receives the benefit of, and is bound by, all provisions herein, including time limits and limitations of liability. Customer is solely responsible for ensuring such parties have received and consented to this Agreement.

2. Scope of Labor and Material Handling Services.

These Terms govern all services performed by AGS Exposition Services, Inc. (“AGS”), including material handling, drayage, storage, transportation, and, if AGS directly offers such services, any labor or related work such as installation and dismantle, rigging, carpentry, cleaning, or similar on-site or off-site event labor. Any other labor services not specifically listed but performed by AGS or its authorized agents are likewise governed by these Terms. Where a venue, facility, or project mandates that certain categories of labor (for example, cleaning, electrical, or rigging) be performed exclusively by another provider, AGS shall not be deemed the provider of those services and shall bear no responsibility or liability for the acts, omissions, or performance of such exclusive contractors.

3. Definitions

“AGS” means AGS Exposition Services, Inc., a Florida corporation, including its agents and employees.

“Carrier” means motor carriers, van lines, air carriers, and air or surface freight forwarders.

“Cold Storage” means storage of Goods in a climate-controlled area, whether or not deemed perishable.

“Accessible Storage” means holding of Goods in an area from which Goods may be removed for replenishment or access during event days or between open hours. Accessible Storage is space-only and is **not** insurance or a bailment, and confers no custody, security, inventory control, or condition guarantee by AGS.

“Consignee” means the party to whom Goods are shipped.

“Customer” means any exhibitor, event participant, or other party requesting Goods or Services from AGS.

“Event Site” means the venue(s) where the relevant event, trade show, or exhibition occurs, including docks and staging areas.

“Goods” means exhibits, property, materials, equipment (including electronic equipment), displays, and any other commodities for which AGS is requested to provide or perform Services (e.g., shipping, drayage, assembly, or disassembly).

“HAZMAT” has the meaning set forth in 49 C.F.R. Parts 171-177, as amended.

“ICCTA” means Part B, 49 U.S.C. §§ 13101-14914 (ICC Termination Act of 1995), as amended. “Services” includes, without limitation, warehousing, storage, transportation, drayage, electrical, rigging, material handling, design, graphics, carpentry, installation and dismantle, and logistics, whether performed by AGS and/or its carriers, contractors, and agents.

“Shipper” means any party tendering Goods to a Carrier for transportation. 4. Customer Obligations

a. Payment for Services. Customer, Shipper, and Consignee are jointly and severally liable for all charges for Services performed by the AGS Parties. Upon placing an order (online, by fax, by phone, or via on-site work order), Customer authorizes AGS to charge any provided credit card for all Goods and Services rendered, including after Customer’s departure.

b. Credit Terms. Unless otherwise agreed in writing by AGS, all charges are due before Goods are delivered or Services performed. AGS may require prepayment or other written guarantees. Failure to pay when due may result in cash-in-advance terms for future orders. AGS may hold Goods for non-payment and assess storage/handling fees. Any balance unpaid 30 days after delivery accrues interest at **1.5% per month** until paid. Customer shall be responsible for all reasonable costs of collection, including attorneys’ fees, experts’ fees, and court costs.



2026 FCCFA Annual Convention
& Trade Show
JW Marriott Turnberry
Miami, FL
July 23 - 25, 2026

Discount Price
Deadline Date
JULY 9th

Method of payment must accompany your order



Terms & Conditions of Contract - Material Handling Services

c. HAZMAT Compliance. Customer must disclose any HAZMAT in its packages; comply with all applicable HAZMAT laws; ensure each package is accurately described, properly marked, addressed, and adequately packaged; provide all DOT-required documentation; and provide/affix all required placards. Customer must provide AGS and Carrier accurate information enabling proper disclosures.

d. Customer-Selected Carriers. Where Customer designates its own Carrier, AGS acts solely as Customer's agent for tender and release. Any delay, loss, damage, refusal, detention, reconsignment, reweigh, add-on charges, or service failures by Customer's Carrier are solely between Customer and that Carrier; Customer shall defend, indemnify, and hold the AGS Parties harmless from all resulting claims, charges, or liabilities. **AGS is not responsible for carrier freight charges, re-ratings, corrected charges, or other tariff adjustments; Customer remains solely liable to the carrier for such amounts.**

5. ICCTA Waiver; Mutual Indemnification

a. ICCTA Waiver. To the extent permissible by law, the parties expressly waive any conflicting rights or remedies under the ICCTA.

b. Customer Indemnification. Except to the extent caused by AGS's gross negligence or willful misconduct, Customer shall defend, indemnify, and hold harmless the AGS Parties from all claims, demands, suits, liabilities, damages, costs, and expenses (including reasonable attorneys', experts', and consultants' fees and court costs) arising out of or related to injury, death, or damage to property other than Goods, and from the acts/omissions of Customer, its agents, contractors (including I&D labor), subtenants, licensees, invitees, or anyone present at Customer's request.

Customer acknowledges the Event Site is an active work zone and all such persons are present at their own risk.

c. AGS Indemnification. Subject to Sections 4 and 5, AGS will defend, indemnify, and hold harmless Customer from third-party claims for injury, death, or damage to property other than Goods, but only to the extent caused by AGS's gross negligence or willful misconduct. This obligation does not apply to claims arising (i) from persons present in areas marked "off limits to exhibitors," or (ii) when persons are present at the facility outside the effective dates/hours of Customer's event space lease.

d. Waiver of Subrogation. Customer waives, and shall cause its insurers to waive, rights of recovery and subrogation against the AGS Parties to the extent permitted by law. Customer shall obtain insurance policy endorsements reflecting such waivers upon AGS's request.

6. Disclaimer and Limitation of Liability

UNDER NO CIRCUMSTANCES SHALL ANY PARTY BE LIABLE FOR SPECIAL, INCIDENTAL, CONSEQUENTIAL, INDIRECT, EXEMPLARY, OR PUNITIVE DAMAGES (INCLUDING LOST PROFITS/INCOME, LOSS OF USE, OR BUSINESS INTERRUPTION). Subject to Section 6, AGS is liable for loss or damage to Goods only if caused **solely and directly** by AGS's **gross negligence or willful misconduct**. AGS is not liable for loss, damage, or delay resulting from acts of God, weather, epidemic/pandemic, supply-chain or transportation disruptions, cyber events, act or default of Customer/Shipper/Carrier/owner, the inherent nature of Goods, public enemy/authority, labor disputes, terrorism, or war.

Reasonable Dispatch. AGS does not guarantee any particular schedule for handling, loading, or release to carriers; Services are provided with **reasonable dispatch**, subject to marshaling, load sequencing, and safety.

Aggregate Cap. For any event, shipment, or project, AGS's total cumulative liability shall not exceed the lesser of (i) the amounts stated in Section 8(a), or (ii) the total fees actually paid to AGS for the specific Services giving rise to the claim. **UNDER NO CIRCUMSTANCES SHALL ANY PARTY BE LIABLE FOR SPECIAL, INCIDENTAL, CONSEQUENTIAL, INDIRECT, EXEMPLARY, OR PUNITIVE DAMAGES (INCLUDING LOST PROFITS/INCOME, LOSS OF USE, OR BUSINESS INTERRUPTION).** Subject to Section 6, AGS is liable for loss or damage to Goods **only** if caused **solely and directly** by AGS's **gross negligence or willful misconduct**. AGS is not liable for loss, damage, or delay resulting from acts of God, weather, epidemic/pandemic, supply-chain or transportation disruptions, cyber events, act or default of Customer/Shipper/Carrier/owner, the inherent nature of Goods, public enemy/authority, labor disputes, terrorism, or war.

7. No Liability for Loss or Damage to Goods

a. Condition of Goods. No liability for uncrated freight, improperly packed freight, glass breakage, concealed damage, ordinary wear and tear, or damage to



2026 FCCFA Annual Convention
& Trade Show
JW Marriott Turnberry
Miami, FL
July 23 - 25, 2026

Discount Price
Deadline Date
JULY 9th

Method of payment must accompany your order



Terms & Conditions of Contract - Material Handling Services

shrink-wrapped Goods. Goods must withstand handling by heavy equipment (e.g., forklifts, cranes, dollies).

b. Receipt of Goods. No liability for Goods received without receipts/freight bills or without piece counts, or for bulk shipments (e.g., UPS, air freight, van lines). Such Goods are delivered to booth without guaranteed piece count or condition.

c. Force Majeure. No liability for loss/damage due to events listed in Section 5 (force majeure and similar causes).

d. Cold Storage. Stored at Customer's sole risk.

e. Empty Storage. No liability for loss or damage to Goods, crates, or contents while containers are in empty storage. Customer must affix AGS "Empty" labels and remove any pre-existing labels.

f. Freight Re-Route / Drayback / Abandonment; Missed Pickup Window. Customer is responsible for accurate outbound paperwork and labels. Goods left on the floor after the event closing deadline—or when Customer's Carrier fails to check in by the published outbound cutoff or within **30 minutes** of the scheduled pickup window—may be removed and shipped or drayed at AGS's discretion and at Customer's expense, including return shipping. If drayed back to a warehouse, a **Service Fee minimum of \$850.00** applies for transportation and/or storage; **drayback fees typically range from \$850 to \$2,500** (movement to local warehouse only; excludes final shipping/handling). After drayback, **storage/demurrage and administrative charges will accrue at AGS's posted rates then in effect** (available at the AGS Service Desk), **per day** with a daily minimum. Items abandoned by exhibitors are subject to a **Service Fee beginning at \$500**, in addition to any venue or Carrier charges. AGS assumes no liability for any re-routing, drayback, storage, or disposal.

g. Concealed Damage / Fragile or Improperly Packaged Goods. No liability for concealed loss/damage, including to glass, electronics, prototypes, original art, uncrated Goods, or improperly packaged/labeled items.

h. Unattended Goods. From inbound receipt through outbound loading—including the entire event term—AGS assumes no liability for loss/damage to unattended Goods. Customer must insure its Goods.

i. Unattended or Attended Booths. AGS is not liable for

any loss or damage while Goods are in Customer's booth at any time, whether the booth is attended or unattended, **and continuing until tender to the Carrier-of-record and documented receipt by that Carrier (e.g., signed bill of lading, dock receipt, or electronic handoff confirmation).** Outbound forms/bills of lading will be checked at pickup; discrepancies in count/condition will be documented.

j. Special Handling Needs. No liability for loss, damage, or delays for Goods requiring special devices or facilities unless AGS received advance notice sufficient to obtain proper equipment. AGS may refuse movement/acceptance when equipment/facility limitations exist. Customer must arrange special needs with AGS (or alternate agents where AGS cannot perform due to contractual or legal limits).

k. Mitigation; Perishables; Unsafe or Leaking Goods. AGS may, but is not obligated to, take reasonable steps to protect perishable, unsafe, or leaking Goods (including segregation, over-packing, neutralization, or **disposal without compensation**). Customer is responsible for all related costs and shall indemnify the AGS Parties for resulting claims.

l. Accessible Storage. Storage charges are for space only and are **not** insurance, a bailment, or a guarantee of custody, security, inventory control, or condition. AGS assumes **no liability** for any loss, damage, theft, misplacement, shrinkage, or deterioration while Goods are in Accessible Storage. Customer remains solely responsible for insuring Goods and accepts all risk. **Daily charges apply at AGS's posted rates then in effect.**

8. Agency Status; Substitution of Carriers

a. Agency Only; Not a Bailee/Shipper. For receipt, handling, temporary storage, and reloading, AGS acts solely as Customer's **agent**, not as a bailee or shipper. If AGS signs any delivery receipt, bill of lading, or similar document, it does so **as Customer's agent**, and Customer retains all liability for loss/damage/theft/delay. **Nothing herein converts AGS into a "motor carrier," "freight forwarder," or other carrier under 49 U.S.C. § 13102, nor imposes liability under 49 U.S.C. § 14706 (Carmack).**

b. Substitution of Carriers. To expedite removal of Goods from the Event Site, AGS may change Customer's designated Carrier if that carrier fails to pick up on time.



2026 FCCFA Annual Convention
& Trade Show
JW Marriott Turnberry
Miami, FL
July 23 - 25, 2026

Discount Price
Deadline Date
JULY 9th

Method of payment must accompany your order



Terms & Conditions of Contract - Material Handling Services

c. Re-weigh / Re-measure Authority. AGS may re-weigh, re-measure, or re-classify shipments and invoice based on actuals, including special handling surcharges per AGS's posted rates.

9. Labor Services; Liability and Supervision

AGS provides labor services—including but not limited to installation, dismantle, rigging, carpentry, and cleaning—subject to these same Terms and Conditions.

When Customer elects supervised labor, AGS's liability is limited to direct physical loss or damage to property caused solely and directly by AGS's gross negligence or willful misconduct, and in no case shall exceed the lesser of (i) the cost of such labor services or (ii) the depreciated value of the affected property.

For dismantle or removal services, Customer acknowledges that AGS did not participate in the original installation and therefore must rely entirely on Customer-supplied information, diagrams, and instructions to identify proper disassembly, packing, and shipping procedures. Customer is responsible for ensuring that all materials, containers, and packing components are in safe, usable condition for dismantle and transport. AGS shall have no liability for damage, loss, or delay arising from incomplete, inaccurate, or inadequate instructions, or from the condition of display assets or packing materials.

Customer is responsible for ensuring that all display materials, structural elements, and accompanying instructions, diagrams, and hardware provided for installation or dismantle are complete, accurate, and suitable for assembly. AGS shall have no liability for loss, damage, or improper setup arising from incomplete, unclear, or faulty exhibitor-supplied information or materials.

When Customer elects unsupervised labor, Customer assumes all risk and responsibility for direction, supervision, and results of the work. AGS shall not be liable for any loss, damage, or injury arising from unsupervised labor, and Customer shall defend, indemnify, and hold harmless AGS and event management (including reasonable defense costs) from all resulting claims.

AGS shall not be responsible for delays, work stoppages, or performance failures caused by union disputes, walkouts, strikes, or other labor actions beyond its control.

AGS may, in its sole discretion, refuse to perform or continue work that, in its judgment, would create an unsafe condition or violate applicable facility, union, or regulatory requirements. Such refusal shall not constitute a breach of these Terms, and Customer remains responsible for all labor ordered up to that point.

10. Measure of Damages; Released Value Option

a. Sole Monetary Relief. If AGS is found liable for loss/damage to Goods, AGS's **maximum** liability is the lesser of: **\$0.50 per pound, \$100 per container, or \$1,500 per shipment.**

b. Labor. For provisions governing AGS's liability and Customer responsibilities for labor services, see the section titled "*Labor Services; Liability and Supervision.*"

c. Released Value Increase (Optional). Prior to service performance and subject to AGS's written acceptance and additional charges, Customer may request a higher released value limit for a specific shipment or project. Any approved increase will be documented in writing, applies only to direct physical loss caused solely by AGS's gross negligence or willful misconduct, and shall not exceed an aggregate cap agreed by the parties. **Declared values or released rates stated on any carrier bill of lading do not alter AGS's liability limits; only a written released-value increase executed by AGS under this §8.c modifies AGS's limits.**

11. Insurance; Claims; Evidence; Legal Action Notices

a. Insurance. AGS IS NOT AN INSURANCE COMPANY AND DOES NOT OFFER OR PROVIDE INSURANCE. Customer is solely responsible for insuring Goods at all times (including storage, transit to/from the Event Site, and while on the floor). **"All Risk" coverage is strongly recommended.** Customer shall maintain at its expense: (i) commercial general liability insurance with limits customary for trade-show exhibitors, naming AGS as an **additional insured** on a primary and non-contributory basis, and (ii) property insurance covering Goods on an "all risk" basis. Certificates/endorsements shall be produced upon request.

b. Notice of Loss or Damage. To preserve a claim, Customer must notify AGS (or its agent) within 24 hours of the occurrence, as evidenced by an **Incident Report** completed on site.



2026 FCCFA Annual Convention
& Trade Show
JW Marriott Turnberry
Miami, FL
July 23 - 25, 2026

Discount Price
Deadline Date
JULY 9th

Method of payment must accompany your order



Terms & Conditions of Contract - Material Handling Services

c. Evidence Required. As a condition precedent to any claim, Customer shall (i) provide time-stamped digital photos/videos of packaging and Goods at hand-off and at discovery of loss/damage; (ii) retain packaging and contents for inspection; (iii) provide serial numbers, model numbers, and invoices; and (iv) make the Goods reasonably available for inspection. Failure to comply voids the claim.

d. Filing a Claim. A claim must be **in writing** and (i) identify the Goods, (ii) assert liability, and (iii) demand a specified/determinable amount.

Deadlines: **event-site claims** within **30 days after event close**; **transit claims** within **30 days after delivery**. **Reports or notations are not claims.** Customer may not withhold or offset amounts owed to AGS due to a dispute; all AGS invoices must be paid **before event close**, and any claim must be pursued separately. AGS may pursue collection regardless of any alleged loss.

Transit Claims. The claim and suit periods in §9(b)–(e) apply to event-site claims only. Claims for loss or damage **in transit** must be filed directly with the Carrier identified on the bill of lading and are governed by the carrier's tariff and applicable law (e.g., Uniform Bill of Lading/Carmack). AGS will make commercially reasonable efforts to provide documentation to facilitate such claims but is **not** the proper party for Carrier claims, and Customer's payment obligations to AGS are not contingent on any Carrier's resolution.

e. Filing of Suit. Any action regarding loss/damage to Goods must be filed **within one (1) year** from AGS's written declination (in whole or part) of a claim.

f. Notice of Legal Action. If an exhibitor threatens legal action, AGS personnel communications may cease and future service to that exhibitor may be suspended.

12. Governing Law; Venue; Dispute Resolution; Waivers

a. Governing Law; Venue; Fees. This Agreement is governed by Florida law. The parties submit to jurisdiction and venue in the **U.S. District Court, Middle District of Florida, Orlando Division, or the State Courts of Orange County, Florida**. In any action arising out of or related to this Agreement (including collection), the prevailing party is entitled to reasonable attorneys' fees and taxable costs at all trial and appellate levels.

b. Pre-Suit Mediation. Except for actions to collect

undisputed sums due, applications for temporary injunctive relief, or small-claims matters, the parties shall first participate in **non-binding mediation** in Orange County, Florida, with a mutually agreed mediator (or, failing agreement, one appointed by the court). Each party bears its own costs; fees are shared equally. A party refusing to mediate after written demand may not recover attorneys' fees otherwise available under this Agreement for the period of refusal.

c. Class Action and Jury Trial Waivers. To the fullest extent permitted by law, **the parties waive any right to a jury trial and waive participation in any class, collective, or representative action**, agreeing that claims shall be brought on an individual basis only.

13. Advanced Warehousing / Temporary or Long-Term Storage

a. Storage terms are set forth in a separate Storage Agreement. If no Storage Agreement is executed, the following applies: AGS's responsibility is limited to ordinary care and diligence; liability exists only for loss or damage caused solely and directly by AGS's gross negligence, capped at the lesser of \$0.50 per pound, \$100 per container, or \$1,500 per shipment (prorated for partial loss by weight). AGS is not responsible for losses due to fire, theft, elements, vandalism, moisture, vermin, mechanical breakdown/failure, freezing/temperature change, or other causes beyond AGS's immediate control; nor for marring/scratching/breakage of glass or other fragile items; nor for mechanical functions of instruments/appliances, even if AGS packs/unpacks them. No special, incidental, indirect, or consequential damages (including lost profits/income) are recoverable. Storage/advance warehousing fees are for space use only; no security or environmental condition guarantees are made. **AGS DOES NOT PROVIDE INSURANCE.** Customer must maintain insurance sufficient to cover its risk.

b. Advance Warehouse Agency and Limitation of Liability. For certain Events or Projects, AGS may, as a convenience to the Customer and Event Management, coordinate or designate an advance warehouse operated by an independent third-party provider ("Warehouse Provider") for the receipt and temporary storage of freight prior to delivery to the Event Site. Such warehousing is provided solely by the Warehouse Provider and not by AGS and is



2026 FCCFA Annual Convention
& Trade Show
JW Marriott Turnberry
Miami, FL
July 23 - 25, 2026

Discount Price
Deadline Date
JULY 9th

Method of payment must accompany your order



Terms & Conditions of Contract - Material Handling Services

offered exclusively as a convenience to facilitate tender of materials to the event or project.

In these cases, AGS acts only as an agent in arranging storage and does not take ownership or control of the facility, personnel, or operations of the Warehouse Provider. Claims for loss, damage, theft, or delay occurring while materials are in the custody of the Warehouse Provider must be filed directly with that provider in accordance with its own terms and procedures. AGS may, at its discretion, assist in facilitating such claims but assumes no liability for the acts, omissions, or conditions of any third-party warehouse or carrier.

The advance warehouse, like the Event Site, is not under the direct control of AGS, and AGS cannot exercise authority or accept responsibility for materials at those locations except during the limited time when goods are in the exclusive physical custody of AGS's material handling labor and equipment (for example, during active handling, transport, or placement on the event floor).

c. Post-Event or Drayback Storage. Following Event close or upon return of freight to AGS facilities, AGS's role transitions from an agent to a warehouseman for any goods held beyond the event period. The following provisions apply to such post-event storage:

d. Warehouseman Status. Upon drayback or where disposition is pending, AGS holds Goods as a warehouseman only, with duties limited to ordinary care; storage, notice, and disposition proceed per this Agreement and applicable law.

e. Warehouseman's Lien. AGS shall have a possessory lien on Goods for all charges and may, after reasonable notice as required by law, sell or otherwise dispose of Goods to satisfy unpaid amounts, applying proceeds to charges and costs of sale.

14. Right to Refuse Service; Safety.

AGS may refuse or suspend Services at any stage if materials or working conditions materially deviate from the condition or information provided, contain prohibited items, or present an unreasonable safety, environmental, or labor risk. This includes circumstances involving unsafe work areas, union jurisdictional disputes, walkouts, or other conditions beyond AGS's control that make continuation of

work impractical or unsafe. This right extends to dismantle-only services where the condition of materials or packing deviates from those disclosed at the time of inspection or request, or where materials cannot be safely handled or packed without damage. If AGS refuses or suspends work, AGS will notify a designated contact if identifiable. Customer must then either (i) correct the issue/missing information on-site, or (ii) handle the materials or labor directly to meet event move-in/move-out requirements. Fees for Services already rendered remain payable. All persons in the Event Site must comply with posted safety rules, restricted areas, and PPE requirements; violations are at Customer's risk.

15. General Provisions

a. Entire Agreement; Amendments. This Agreement constitutes the entire agreement regarding its subject matter and supersedes inconsistent prior terms. Amendments must be in a signed writing (other than unilateral changes by AGS made with advance notice under "Changes").

b. Severability. If any provision is found unenforceable, it will be modified to the minimum extent necessary to be enforceable; the remainder stays in effect.

c. No Waiver. A party's failure or delay to enforce any provision is not a waiver.

d. Headings. Headings are for convenience only and do not affect interpretation.

e. Third-Party Beneficiaries. The AGS Parties (carriers, contractors, and their agents) are intended beneficiaries of Sections 1, 3-12.

f. Electronic Signatures; Notices. The parties consent to electronic signatures and to receiving notices by email to the addresses provided in ordering documents; notices are deemed given when sent (or, for mailed notices, upon delivery confirmation).

Official Transportation Provider

via the ABF Freight® Network

Let ArcBest® make your next trade show the easiest you have ever attended!

We have over 90 years of experience in the freight industry and a dedicated Trade Show division with service through North America through the ABF Freight® network.

Choose guaranteed, expedited shipping solutions – air or ground – with special discounted rates for your inbound and outbound shipments.

For personalized quotes, please call

800-654-7019

Our Services Include:

Priority handling of your inbound and outbound shipments

Guaranteed expedited air and ground services

LTL Ground Transportation

International Transportation

Trust your important trade show shipment to the leader in exhibition transportation services.

ArcBest®
More Than Logistics™

REQUEST FOR INFORMATION

ArcBest® Trade Show Services

Exhibiting Company _____ Contact Name _____

Title _____ Email _____ Phone _____

SHIPPER INFORMATION

Company _____

Address _____

City _____ State _____ Zip _____

Pickup Date/Time _____

FREIGHT INFORMATION

Piece Count and Type _____

Total Weight _____

Dimensions (L) _____ (W) _____ (H) _____

SHIP TO: Warehouse Show Site

Show Name _____

Booth No. _____

Contractor _____

Show Dates _____

Address _____

City _____ State _____ Zip _____

Delivery Date _____

ADDITIONAL INFORMATION

Residential Pickup Inside Pickup

Liftgate Dock

Would you like an ArcBest Trade Show Coordinator to contact you with a quote or information?

YES NO

If you are faxing this form, please print a copy, complete the requested information, and then fax to (844) 718-7620.

800-654-7019
tradeshow@arcb.com | arcb.com



8401 McClure Drive • Fort Smith, AR • 72916

EXPERIENCE

pinnacle | e
LIVE™

For Electric, Internet, & AV needs,
please visit the below link to order:

<https://exhibitors.pinnaclelive.com/venues/224/events/195>

Need help?

1030@pinnaclelive.com